

# Braking Performance *can be a* GAME OF INCHES



**Ausco's new wet parking and service brake combines strong holding power with precise braking control.**

In braking, control is just as important as power. Ausco developed its new combination parking and service brakes with both in mind. The new brakes feature high static brake capacity that can hold the largest mobile equipment or crane. Designed for a wide variety of applications including oil well cranes, underground mining equipment and airport ground support equipment, the brakes also feature a simple annular piston design that's easy to bleed, has fewer parts than previous models and delivers precise braking control.

The new brakes are available in both SAE B and C sizes with torques up to 7,000 in lbs. High-energy metallic linings and wet flow-through or sump cooling ensure long life and durability to meet your most demanding

requirements at a surprisingly affordable price.

For more about how Ausco's new combination parking and service brake can give your mobile

equipment or crane more braking control, contact Ausco at [\(269\) 926-0700](tel:2699260700) or [www.auscoproducts.com](http://www.auscoproducts.com).

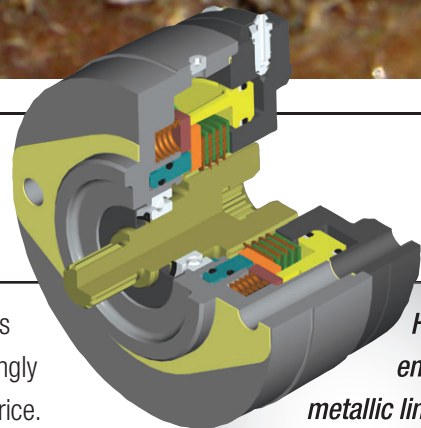

*High-energy metallic linings and wet flow-through or sump cooling ensure long life.*



[www.auscoproducts.com](http://www.auscoproducts.com)