

1. THIS DRAWING IS MEANT TO PROVIDE CUSTOMER MOUNTING DATA ONLY. ALL DIMENSIONS ARE REFERENCE ONLY UNLESS OTHERWISE NOTED.
2. THE TORQUE INFORMATION CONTAINED IN THIS DOCUMENT IS FOR REFERENCE ONLY. IT IS RECOMMENDED THAT THIS BRAKE BE TESTED IN THE SPECIFIC APPLICATION TO VERIFY PERFORMANCE.
3. MAXIMUM OPERATING PRESSURE IS 2250PSI. PRESSURE SPIKES AND SURGES NOT TO EXCEED 3000 PSI.

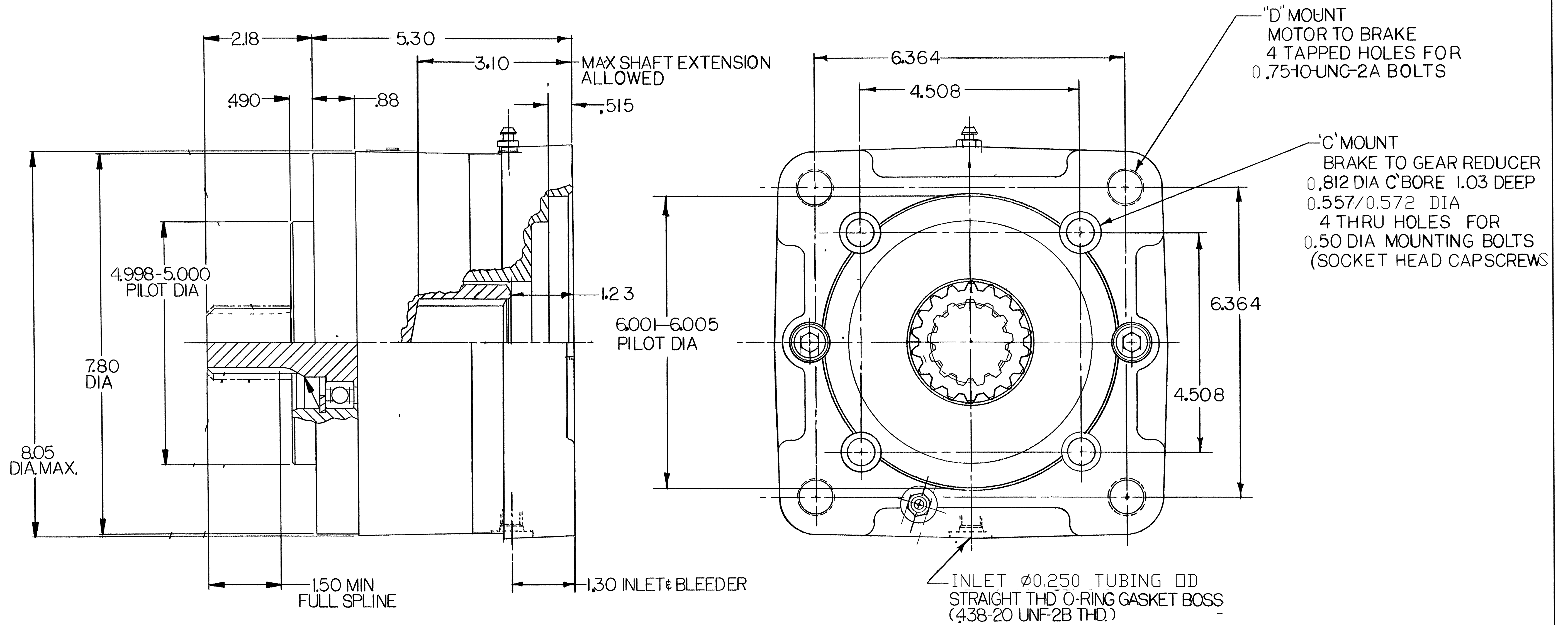

KAD	A	21246	RELEASE FOR PRODUCTION	01-16-03	SJS
CHKR	SYM	ECD	DESCRIPTION	DATE	BY

DO NOT SCALE THIS DRAWING
 PROPRIETARY DATA: NOT TO BE
 DISCLOSED, USED, OR REPLICATED
 FOR PROMOTION OR MANUFACTURING
 PURPOSES, EXCEPT AS AUTHORIZED
 IN WRITING BY AUSD, INC.



D	C	5000	165	13T 8/16	14T 12/24	PROJECT	DATE	PART NAME
MOTOR	REDUCER	RATED TORQUE (LB IN)	RELEASE PRESSURE (PSI)	INPUT (INTERNAL)	OUTPUT (EXTERNAL)	RFE	01-16-03	MULTI-DISC BRAKE "DRY"
MOUNTING FLANGE SAE J744				SPLINE DATA		DESIGNER	SCALE	PART NUMBER
						S. SHDUP	1X	CC82124