

THE MULTI-DISC BRAKE IS A SPRING-APPLIED, HYDRAULICALLY RELEASED BRAKE. HYDRAULIC PRESSURE IS REQUIRED TO RELEASE OR "HOLD OFF" THE BRAKE. NORMAL OPERATION IS TO HAVE THE BRAKE PRESSURIZED IN THE RELEASED POSITION WITH THE VEHICLE HYDRAULIC SYSTEM RUNNING. ANY FUNCTION WHICH REDUCES THE HYDRAULIC SYSTEM BELOW THE RELEASE PRESSURE OF THE BRAKE WILL CAUSE THE BRAKE TO BE APPLIED.

CAUTION:

FOR CORRECT OPERATION, HYDRAULIC PRESSURE TO THE BRAKE MUST FALL TO ZERO PSI. ANY RESIDUAL BACK PRESSURE APPLIED TO THE BRAKE WILL DEGRADE FUNCTION AND MAY RESULT IN A HAZARDOUS CONDITION.

INSTALLATION INFORMATION:

1. ASSEMBLE BRAKE BETWEEN MOTOR AND GEARBOX. PLACE MOUNTING GASKETS ON THE MOUNTING FACES BEFORE ASSEMBLY. IF NEEDED, BRAKE SHAFT CAN BE ROTATED BY APPLYING HYDRAULIC PRESSURE TO THE PISTON INLET PORT.
2. INSERT TWO 1/2" DIA. BOLTS (GRADE 5) THROUGH THE MOTOR FLANGE, THE GASKET, THE BRAKE, AND INTO THE THREADED HOLES IN THE GEAR REDUCER. MAKE SURE THAT THE BOLTS ARE NOT TOO LONG, SO THEY DO NOT BOTTOM OUT IN THE THREADED HOLES OF THE GEAR REDUCER.
3. TO PREVENT BINDING, RUN THE BOLTS IN ALTERNATELY UNTIL SNUG. TORQUE BOLTS TO 55-65 FT.-LBS.
NOTE: THE SHAFTS MUST SLIDE TOGETHER FREELY. DO NOT USE THE BOLTS TO FORCE THEM TOGETHER.
4. WITH MOTOR AND BRAKE BOLTED TOGETHER INTO POSITION, CONNECT INLET HYDRAULIC LINE. BRAKE INLET IS 1/4" LINE STRAIGHT THREAD O-RING BOSS (7/16-20 UNF).

BRAKE DISASSEMBLY INFORMATION:

1. DISASSEMBLE IN THE FOLLOWING ORDER: BOLTS (ALTERNATELY), POWER PLATE, GASKET, STATIONARY DISCS, ROTATING DISCS, PRIMARY DISC, TORQUE PINS, COMPRESSION SPRINGS, AND SPRING RETAINER.
2. FURTHER DISASSEMBLY IS NOT RECOMMENDED AND SHOULD NOT BE ATTEMPTED UNLESS NECESSARY TO REPLACE THE BEARING, THE SEAL, OR THE SHAFT.
NOTE: IF THE BEARING AND SEAL ARE REMOVED FOR ANY REASON, BOTH MUST BE REPLACED.
 - 2a. REMOVE SNAP RINGS AS NEEDED.
 - 2b. SEAL CAN BE REMOVED BY PRYING IT OUT WITH AN APPROPRIATE TOOL. TAKE CARE NOT TO DAMAGE THE BORE.
 - 2c. SHAFT CAN BE REMOVED BY PRESSING IT OUT WITH A SHOP PRESS.
3. REMOVE THE PISTON FROM THE POWER PLATE BY INTRODUCING LOW PRESSURE AIR (15 psi) INTO THE HYDRAULIC INLET. MAKE SURE THE PISTON IS DIRECTED AWAY FROM THE OPERATOR. DO NOT REMOVE O-RINGS AND BACKUP RINGS FROM THE O.D. AND I.D. GROOVES OF THE PISTON UNLESS REPLACEMENT IS NECESSARY, BECAUSE THEY WILL BE DAMAGED.

ASSEMBLY INFORMATION:

IMPORTANT: THERE MAY BE MORE PARTS IN A SERVICE KIT THAN YOUR BRAKE REQUIRES. CHECK THE PARTS LIST CAREFULLY FOR THE EXACT QUANTITY. SPACE THE SPRINGS AS SHOWN ON THE SPRING ORIENTATION VIEW.

USE THE REVERSE OF THE DISASSEMBLY PROCEDURE WITH THE FOLLOWING NOTES AND ADDITIONS:

1. WORN AND DAMAGED O-RINGS AND BACKUP RINGS MUST BE REPLACED PRIOR TO RE-ASSEMBLY.
2. LUBRICATE THE PISTON BORE OF THE POWER PLATE, THE PISTON, AND THE O-RINGS WITH SYSTEM HYDRAULIC FLUID PRIOR TO RE-ASSEMBLY.
3. PISTON ASSEMBLY:
ASSEMBLE PISTON INTO POWER PLATE USING A SHOP PRESS. TAKE CARE NOT TO DAMAGE THE O-RING OR TEFLON BACKUP RINGS. VISUALLY ALIGN THE CENTER OF THE CUTOUTS IN THE PISTON WITH THE TORQUE PIN HOLES IN THE POWER PLATE.
CAUTION: THE DEPTH THE PISTON IS INSTALLED INTO THE POWER PLATE IS CRITICAL. THE SURFACE OF THE PISTON AT THE CUTOUTS MUST BE FLUSH TO 0.120 BELOW THE SURFACE OF THE POWER PLATE, OR PISTON MAY COCK RESULTING IN A COMPLETE LOSS OF BRAKING.
4. BEARING ASSEMBLY:
USE A SHOP PRESS TO PRESS THE BEARING ONTO THE SHAFT. PRESS ONLY ON THE INNER RACE OF THE BEARING. BEARING IS A SLIP FIT TO THE HOUSING.
5. LIP SEAL ASSEMBLY:
LIP OF SEAL MUST FACE TOWARD THE BEARING. SEE CUTAWAY VIEW FOR SEAL ORIENTATION DETAIL.
6. ROTATING, STATIONARY, AND PRIMARY DISC ASSEMBLY:
ROTATING DISCS MUST BE CLEAN & DRY. THE LINING MATERIAL AND MATING SURFACES OF THE STATIONARY DISCS MUST BE THOROUGHLY CLEAN AND FREE FROM DEBRIS. WORN OR SCARRED ROTATING DISCS MUST BE REPLACED.
7. INSTALL BOLTS IN THE POWER PLATE. TIGHTEN SEQUENTIALLY ONE TURN AT A TIME UNTIL POWER PLATE IS PROPERLY SEATED. TORQUE BOLTS TO 80-90 FT.-LBS.

SERVICE KIT INFORMATION:

BEARING KIT: PK - 1320 - INCLUDES SEALS, RETAINING RINGS, AND BEARINGS.

STACK KIT: PK - 1358 - INCLUDES TORQUE PINS, PRIMARY, STATIONARY, ROTATING DISCS AND COMPRESSION SPRINGS.

O-RING KIT: PK - 1359 - INCLUDES O-RINGS, BACKUP RINGS, AND INTERNAL GASKET.

GASKET KIT: PK - 1325 - INCLUDES EXTERIOR GASKET(S).



BRAKE NUMBER 76470 PARTS LIST

ECO 22171 REV C

ITEM	PART	DESCRIPTION	QTY
1	28426	GASKET	2
2	75822	HOUSING	1
3	35875	TORQUE PIN	2
4	74554	SPRING RETAINER	1
5	28962	COMPRESSION SPRING	7
6	28963	COMPRESSION SPRING	7
7	34574	BALL BEARING	1
8	74579	SHAFT	1
9	37144	OIL SEAL	1
10	75540	RETAINING RING	1
11	74553	PRIMARY DISC	1
12	74771	ROTATING DISC	4
13	74552	STATIONARY DISC	4
14	75093	GASKET	1
15	27966	BACKUP RING	1
16	27777	O-RING	1
17	27808	O-RING	1
18	27967	BACKUP RING	1
19	29035	BLEEDER	1
20	75109	PISTON	1
21	75499	POWER PLATE	1
22	73594	HEX HEAD BOLT	4
23	74877	WASHER	4
24	28435	PROTECTIVE PLUG	1

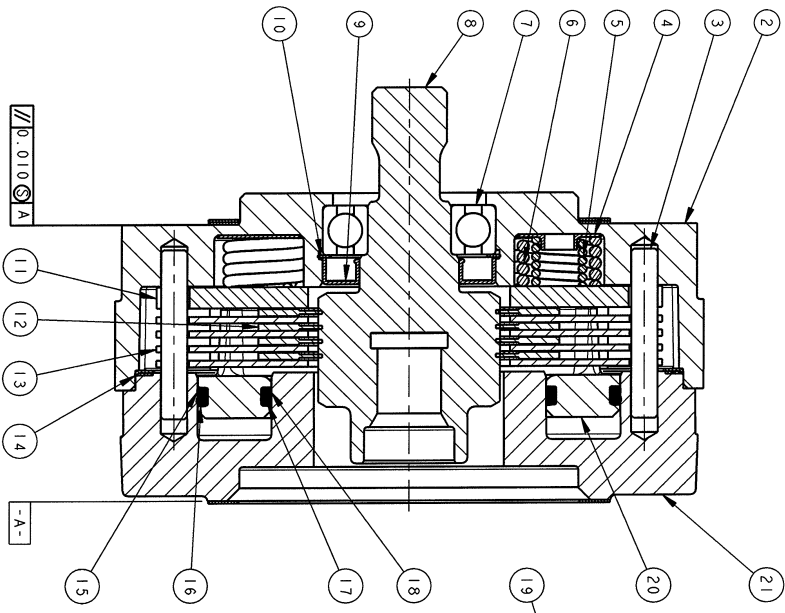
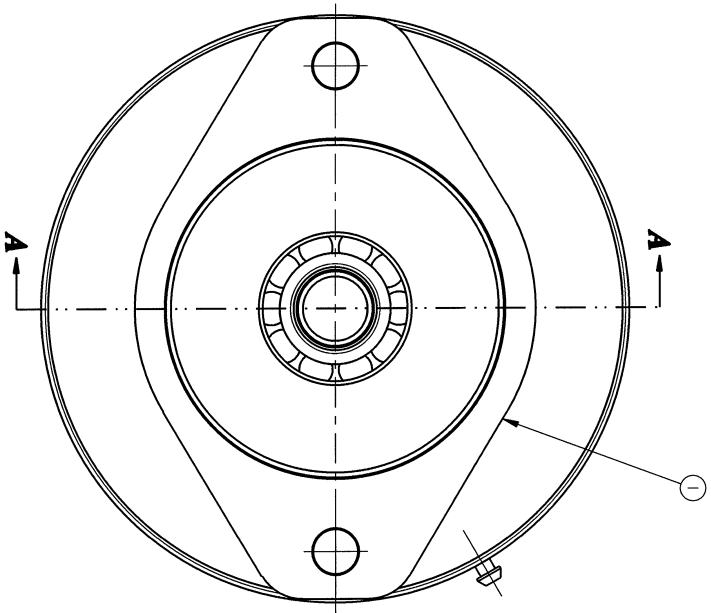

SECTION A-A

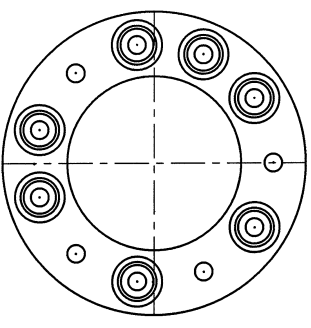
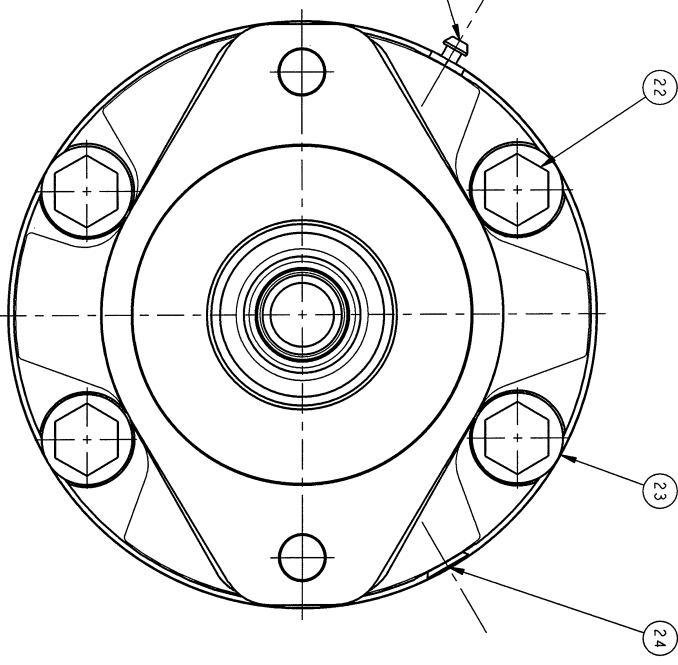

NESTED SPRING ORIENTATION
NO SCALE



STANDARD WET OR DRY MULTI-DISC BRAKES GENERAL ASSEMBLY VIEW

NOTE: THIS DRAWING PROVIDES GENERAL GUIDELINES AND ASSEMBLY INFORMATION ON AISCO MULTI-DISC BRAKES. CONFIGURATION OF BRAKES VARIES FROM MODEL TO MODEL. CONSULT YOUR BRAKES SERVICE NOTES, BILL OF MATERIAL, AND CUTAWAY VIEW FOR EXACT DETAILS.

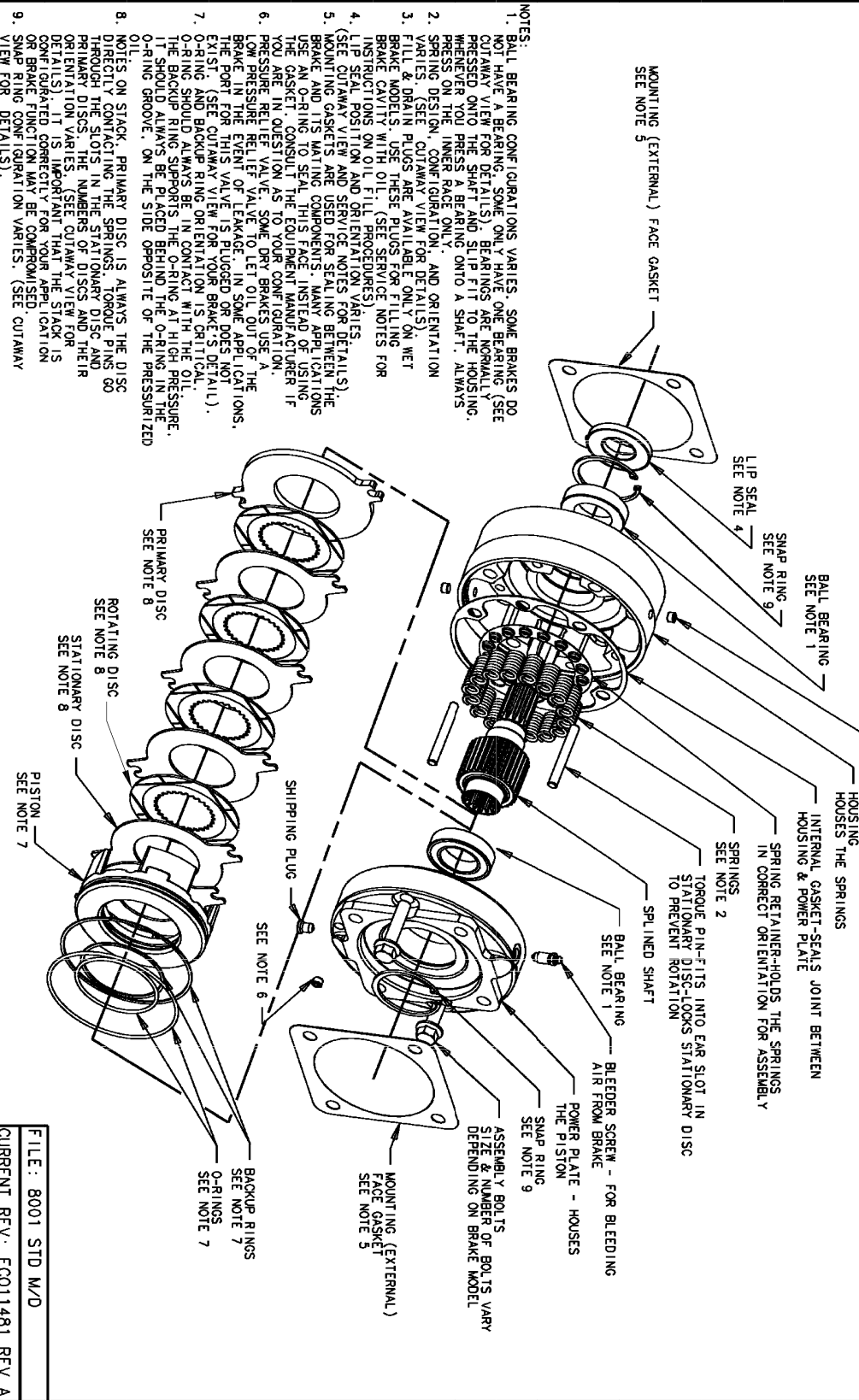

FILE: 8001 STD M/D
CURRENT REV: ECO11481 REV A