



BRAKE NUMBER 92699 SERVICE NOTES

ECO 29569 REV J

THIS MULTI-DISC BRAKE IS A HYDRAULICALLY APPLIED SPRING RELEASED BRAKE. HYDRAULIC PRESSURE IS REQUIRED TO APPLY THE BRAKE FOR SERVICE. NORMAL OPERATION IS TO HAVE THE BRAKE OFF WITHOUT HYDRAULIC INPUT.

CAUTION:

FOR CORRECT OPERATION, THE HYDRAULIC PRESSURE MUST FALL TO ZERO TO ALLOW "FREE-RUNNING CONDITION." ANY BACK PRESSURE WILL RESULT IN A PARTIALLY APPLIED BRAKE. IN THIS CONDITION, VEHICLE MOTION MAY CAUSE PREMATURE LINING WEAR, WHICH MAY RESULT IN A HAZARDOUS CONDITION.

INITIAL INSTALLATION INFORMATION:

1. ASSEMBLE BRAKE TO VEHICLE. SLIDE BRAKE OVER AXLE SPLINE, ALIGNING THE INTERNAL SPLINES OF THE BRAKE WITH THE SPLINES OF THE AXLE. POSITION BRAKE SO THAT THE BRAKE LINE FITTINGS ARE AT THE TOP OF THE BRAKE FOR BLEEDING PURPOSES.
2. PLACE THE MOUNTING BRACKETS ON THE INBOARD SIDE OF THE AXLE MOUNTING FLANGE. INSERT FOUR LUBRICATED 5/16-18 HEX HEAD BOLTS (GRADE 8) THROUGH THE MOUNTING BRACKETS, THROUGH THE AXLE MOUNTING FLANGE, AND INTO THE THREADED HOLES IN THE BRAKE. TORQUE HEX HEAD BOLTS TO 220-245 IN-LB (25-28 Nm).
3. ATTACH BRAKE LINE TO BRAKE. WITH BRAKE IN POSITION, CONNECT INLET BRAKE LINE. BRAKE INLET IS M10 X 1.0 BANJO BOLT AND PORT. USE BRASS WASHERS ON BOTH SIDES OF BANJO BOLT HOSE FOR PROPER SEALING.
4. BLEED BRAKE TO ELIMINATE ANY AIR IN THE BRAKE LINES.
5. FOR WHEEL ASSEMBLY, FOLLOW VEHICLE MANUFACTURER'S INSTRUCTIONS.
6. GREASE OUTBOARD SEALS BY INSTALLING GREASE INTO FRONT GREASE FITTING UNTIL IT RUNS OUT THE FRONT SHAFT SEAL. TURN HUB 1/4 TURN AND REPEAT GREASING THREE TIMES.

BRAKE DISASSEMBLY INFORMATION:

1. DISASSEMBLE IN THE FOLLOWING ORDER: BOLTS, INPUT SEAL, RETAINING RING, THRUST WASHER, POWER PLATE ASSEMBLY WITH BALL BEARING, ROTATING DISCS, STATIONARY DISCS, COMPRESSION SPRINGS, AND TORQUE PINS.
NOTE: INPUT SEAL IS NOT TO BE REUSED. IT MUST BE REPLACED.
2. PISTON CAN BE REMOVED FROM POWER PLATE BY INTRODUCING LOW PRESSURE AIR (15 PSI [1 BAR]) TO THE INLET PORT. MAKE SURE THE PISTON IS DIRECTED AWAY FROM OPERATOR. DO NOT REMOVE THE O-RINGS FROM THE GROOVES OF THE PISTON UNLESS REPLACEMENT IS NECESSARY. REMOVAL WILL DAMAGE THE O-RINGS.
3. REMOVE C-RING AND BALL BEARING FROM POWER PLATE ASSEMBLY. BEARING WILL NEED TO BE REPLACED.
4. FURTHER DISASSEMBLY IS NOT RECOMMENDED AND SHOULD NOT BE ATTEMPTED UNLESS NECESSARY TO REPLACE THE TAPERED ROLLER BEARING, THE SEALS, OR THE HUB.
NOTE: IF THE HUB IS REMOVED FOR ANY REASON, THE TAPERED ROLLER BEARING AND SEALS MUST BE REPLACED.
 - 4a. HUB CAN BE REMOVED BY PRESSING IT OUT WITH A SHOP PRESS.
NOTE: SEALS WILL BE PULLED OUT OF BRAKE ALONG WITH HUB AND TAPERED ROLLER BEARING CONE. TAKE CARE NOT TO DAMAGE THE SEAL BORES.
 - 4b. TAPERED ROLLER BEARING CONE CAN BE REMOVED BY USING A PROPER BEARING PULLING TOOL.

ASSEMBLY INFORMATION:

USE THE REVERSE OF THE DISASSEMBLY PROCEDURE WITH THE FOLLOWING NOTES AND ADDITIONS:

1. WORN OR DAMAGED O-RINGS MUST BE REPLACED PRIOR TO RE-ASSEMBLY.
2. LUBRICATE O-RINGS WITH A PETROLEUM BASED FLUID OR DOW CORNING 200.
3. BEARING ASSEMBLY:
ASSEMBLE THE BEARINGS TO THE HOUSING AND POWER PLATE ACCORDINGLY. NOTE PROPER ORIENTATION OF TAPERED ROLLER BEARING.
4. LIP SEAL ASSEMBLY:
ASSEMBLE SEALS TO HOUSING AND POWER PLATE ACCORDINGLY. SEE CUTAWAY VIEW FOR SEAL ORIENTATION DETAIL.
5. ROTATING, STATIONARY, AND PRIMARY DISC ASSEMBLY:
ROTATING DISCS MUST BE CLEAN. THE LINING MATERIAL AND MATING SURFACES OF THE STATIONARY DISCS MUST BE THOROUGHLY CLEAN AND FREE FROM DEBRIS. WORN OR SCARRED ROTATING DISCS MUST BE REPLACED. ASSEMBLE THE DISC STACK AS SHOWN IN THE DISC STACK ORIENTATION VIEW.
6. PISTON ASSEMBLY:
ASSEMBLE PISTON INTO POWER PLATE USING A SHOP PRESS. TAKE CARE NOT TO DAMAGE THE O-RINGS. PRESS THE PISTON INTO THE BORE UNTIL IT BOTTOMS OUT.
7. FLIP THE POWER PLATE ASSEMBLY AND PLACE ONTO HOUSING ASSEMBLY. INSTALL LUBRICATED BOLTS INTO POWER PLATE. TIGHTEN SEQUENTIALLY ONE TURN AT A TIME UNTIL POWER PLATE IS PROPERLY SEATED. TORQUE BOLTS TO 33-36 FT-LBS [45-49 Nm].
8. USING A SHOP PRESS, ASSEMBLE HUB TO BRAKE.
9. SELECT THRUST WASHER TO ACHIEVE 0.001-0.008" [0,025-0,203 mm] HUB END PLAY.
10. THRUST WASHER MUST BE ASSEMBLED IN LOCATION SHOWN ON CUTAWAY VIEW.
11. OIL FILL PROCEDURE:
ADD 240±10 mL AW68 OF HYDRAULIC OIL.

SERVICE KIT INFORMATION:

IMPORTANT: THERE MAY BE MORE PARTS IN A SERVICE KIT THAN YOUR BRAKE REQUIRES. CHECK THE PARTS LIST CAREFULLY FOR THE EXACT QUANTITY.

- BEARING KIT: PK - 2035 - INCLUDES SEALS, RETAINING RINGS, AND BEARINGS.
- THRUST WASHER KIT: PK - 2231 - INCLUDES VARIOUS THRUST WASHER SIZES TO SET END PLAY.
- STACK KIT: PK - 2036 - INCLUDES TORQUE PINS, STATIONARY DISCS, ROTATING DISCS, AND COMPRESSION SPRINGS.
- O-RING KIT: PK - 2037 - INCLUDES ALL O-RINGS.
- STUD KIT: PK - 2233 - INCLUDES STUDS.

PRO/E

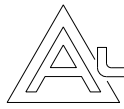

AUSCO BRAKE NO. 92699 PARTS LIST

ECO 29569 REV J

ITEM	PART	DESCRIPTION	QTY
1	90757	TORQUE PIN	4
2	93025	COMPRESSION SPRING	2
3	26930	PROTECTIVE PLUG	1
4	92573	BLEEDER CAP	1
5	33425	BLEEDER SCREW	1
6	75072	STATIONARY DISC	4
7	90730	ROTATING DISC	3
8	92572	GREASE FITTING CAP	1
9	86935	GREASE FITTING	1
10	94444	STUD	5
11	92351	OIL SEAL	1
12	92350	OIL SEAL	1
13	92738	HUB	1
14	92701	HOUSING	1
15	92725	TAPERED ROLLER BEARING (CONE)	1
16	92724	TAPERED ROLLER BEARING (CUP)	1
17	92563	HEX HEAD O-RING BOSS PLUG	2
18	92596	O-RING	1
19	92703	POWER PLATE	1
20	91035	O-RING	1
21	92706	PISTON	1
22	91930	O-RING	1
23	92870	BALL BEARING	1
24	92547	O-RING	1
25	90767	HEX BOLT	4
26	92402	OIL SEAL	1
27	90725	MOUNTING BRACKET	2
28	93665	RETAINING RING	1
29	93754	THRUST WASHER	1
30	93664	C-RING	1
31	92776	HEX HEAD BOLT	6
32	73464	WASHER	6
33	32201	O-RING	6

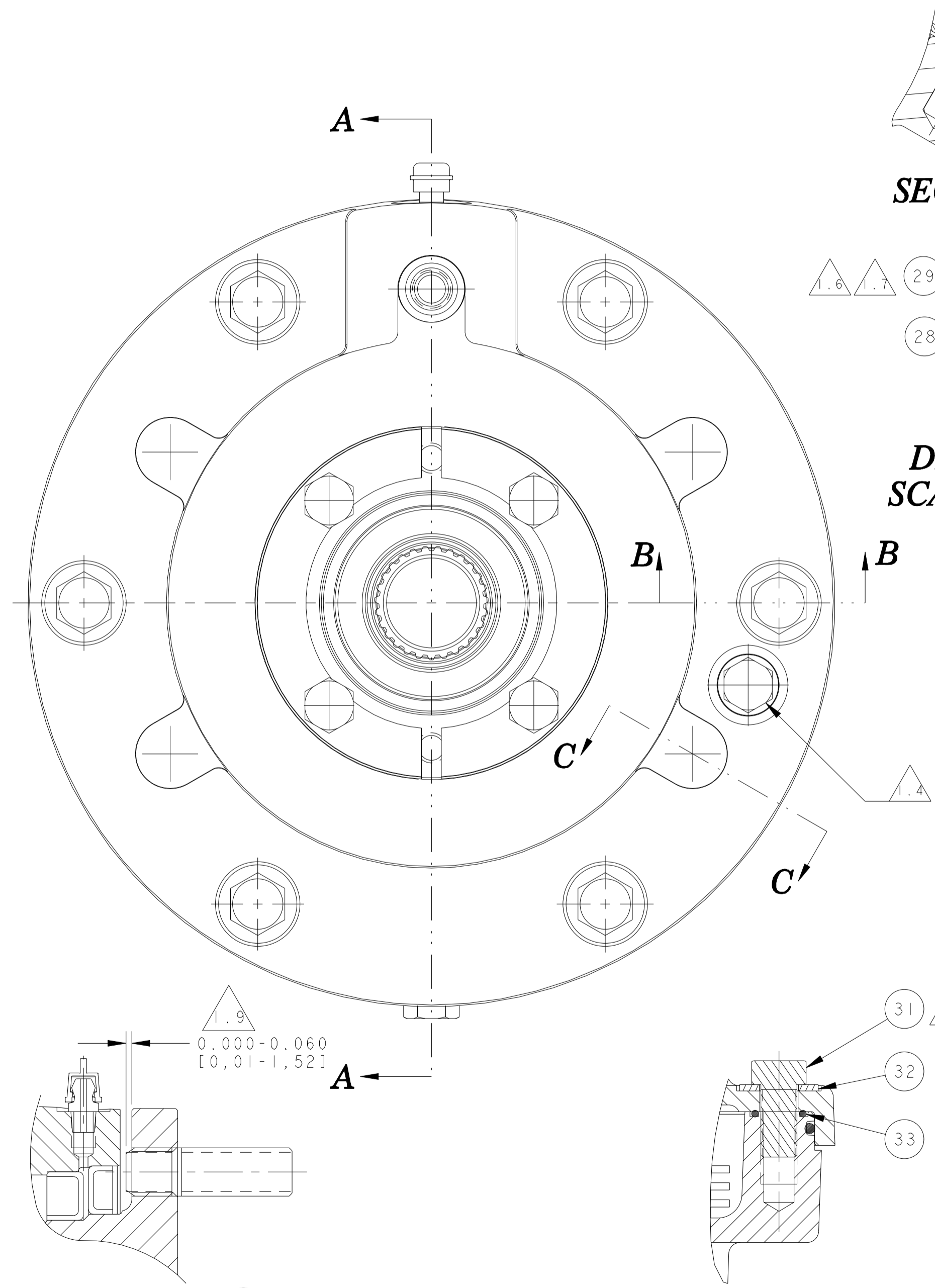

DETAIL Y (J2)

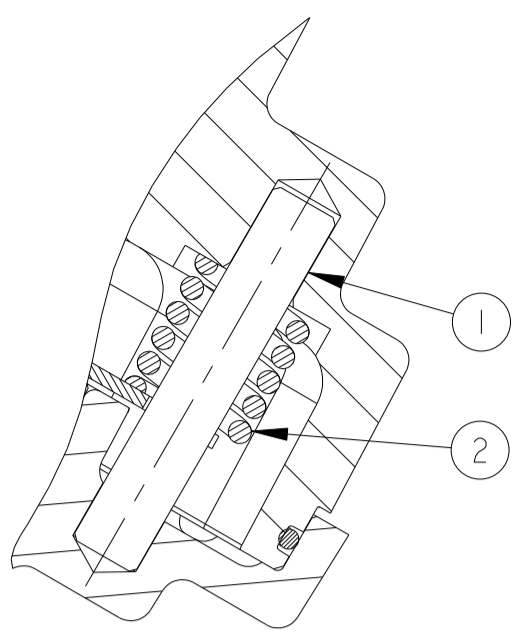

SECTION C-C

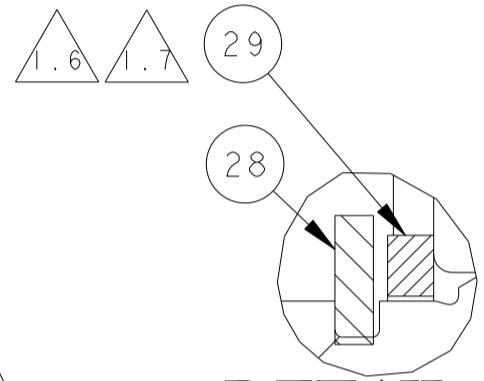

DETAIL Z
SCALE 4.000

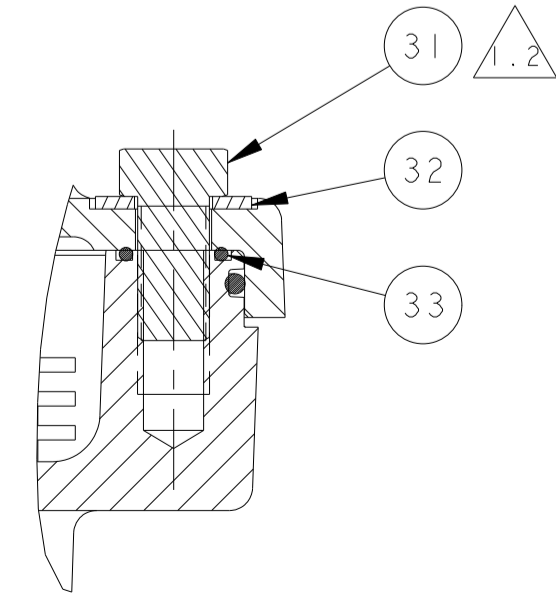

SECTION B-B

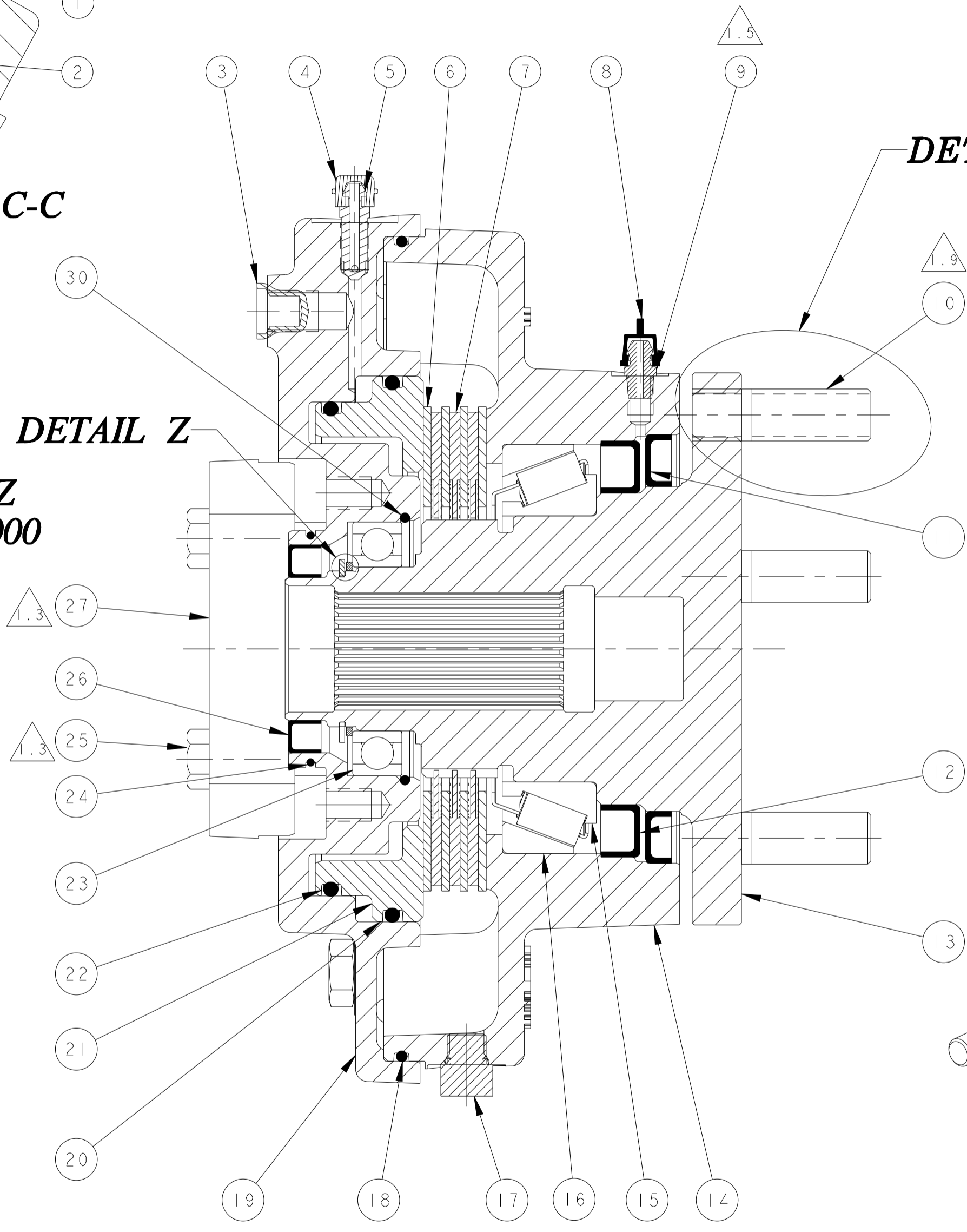

SECTION A-A

DETAIL Y

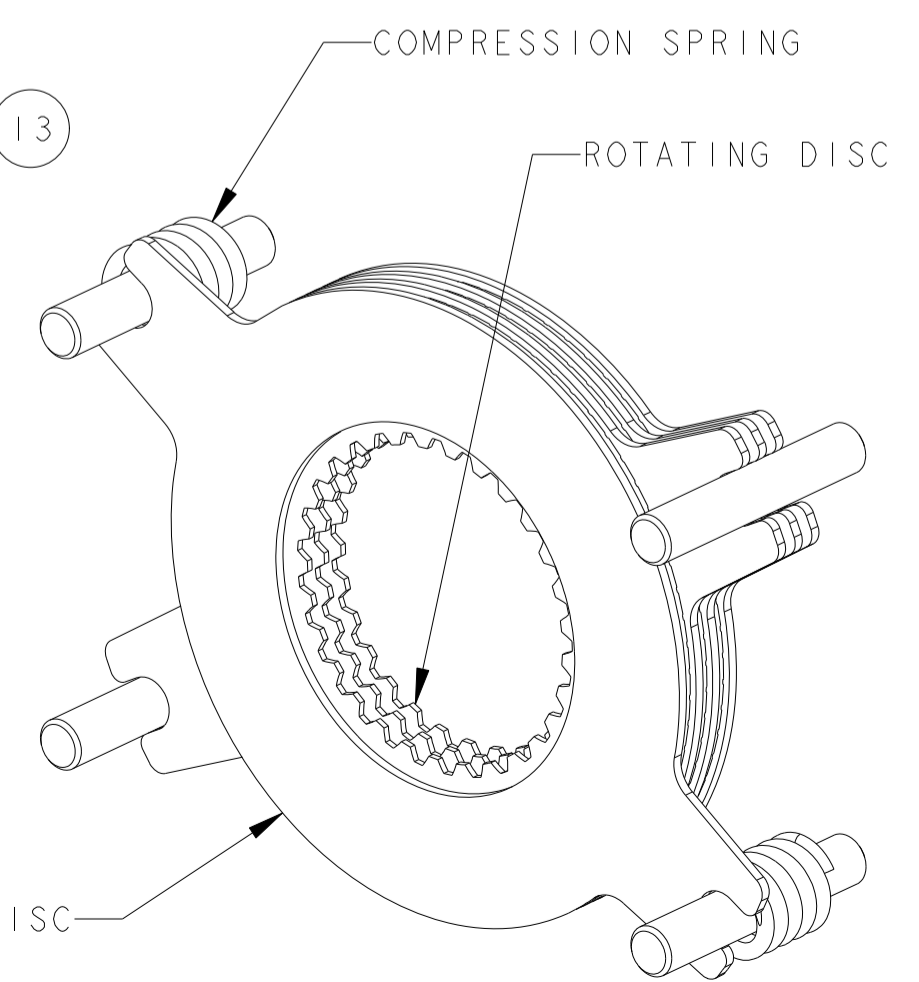

DISC STACK ORIENTATION VIEW
SCALE 0.750