

THE FAILSAFE BRAKE IS SPRING LOADED TO APPLY THE BRAKE AND HYDRAULIC PRESSURE IS REQUIRED TO RELEASE OR "HOLD OFF" THE BRAKE. NORMAL OPERATION IS TO HAVE THE BRAKE PRESSURIZED RUNNING. ANY FUNCTION WHICH REDUCES THE HYDRAULIC SYSTEM PRESSURE BELOW THE RELEASE PRESSURE OF THE BRAKE WILL CAUSE THE BRAKE TO BE APPLIED.

INSTALLATION INFORMATION:

1. REMOVE NUT AND WASHER FROM THE SHAFT.
2. INSTALL YOKE, WASHER AND NUT. TORQUE NUT TO 275-325 FT-LB [373-440 Nm].
3. MOVE BRAKE INTO POSITION, ALIGN MOUNTING BOLT HOLES, AND INSERT FOUR NON-LUBRICATED 16mm OR 5/8" BOLTS THROUGH HOLES IN EACH MOUNTING FOOT.

TIGHTEN BOLTS ALTERNATELY UNTIL SNUG, THEN TORQUE AS FOLLOWS:
5/8" (GRADE 5) 150-165 FT-LBS [203-224 Nm]
(GRADE 8) 215-230 FT-LBS [292-312 Nm]
16 mm (CLASS 8.8) 165-185 FT-LBS [224-251 Nm]
(CLASS 10.9) 230-255 FT-LBS [312-346 Nm]
4. SLIDE YOKE OVER SHAFT.
5. CONNECT VEHICLE DRIVELINE TO BRAKE YOKES.
6. CONNECT HYDRAULIC SUPPLY LINE TO POWER PLATE INLET.
7. REMOVE SIDE OIL FILL PLUG AND FILL BRAKE WITH HYDRAULIC 56 OIL UNTIL OIL RUNS OUT OF PORT. REPLACE PLUG.

BRAKE DISASSEMBLY INFORMATION:

1. REMOVE BRAKE FROM MOUNTING POSITION AND REMOVE YOKES.
2. POSITION BRAKE WITH POWER PLATE UP (THE SIDE WITH MOUNTING FEET).
3. REMOVE ASSEMBLY BOLTS ALTERNATELY KEEPING POWER PLATE PARALLEL TO THE HOUSING TO PREVENT DAMAGE TO BEARINGS. USE EXTREME CAUTION: SPRINGS CAN CAUSE POWER PLATE ASSEMBLY TO POP OFF HOUSING.
4. AFTER THE ASSEMBLY BOLTS HAVE BEEN REMOVED, REMOVE POWER PLATE SUB ASSEMBLY FROM BRAKE.
5. REMOVE SHAFT AND DISC STACK FROM THE BRAKE. IF THE STACK IS TO BE SERVICED, USE A SHOP PRESS. REMOVE THE BEARING CONES FROM SHAFT.
6. REMOVE PRIMARY DISC, SPRINGS, AND SPRING RETAINER FROM HOUSING SPRING POCKET.
7. REMOVE PISTON FROM POWER PLATE BY INTRODUCING LOW-PRESSURE AIR, (15 PSI [1 BAR]), INTO HYDRAULIC INLET. MAKE SURE THE PISTON IS DIRECTED AWAY FROM THE OPERATOR. REMOVE O-RINGS FROM THE O.D. AND I.D. OF THE GROOVE OF THE PISTON.

NOTE: IF THE BEARING AND/OR SEALS ARE REMOVED, BOTH MUST BE REPLACED. SEAL CAN BE REMOVED BY PRYING IT OUT WITH AN APPROPRIATE TOOL. CARE MUST BE TAKEN NOT TO DAMAGE THE BORE.

ASSEMBLY INFORMATION:

IMPORTANT: THERE MAY BE MORE PARTS IN A SERVICE KIT THAN YOUR BRAKE REQUIRES. CHECK THE PARTS LIST CAREFULLY FOR THE EXACT QUANTITY.

USE THE REVERSE OF THE DISASSEMBLY PROCEDURE WITH THE FOLLOWING NOTES AND ADDITIONS:

1. WORN AND DAMAGED O-RINGS OR WORN BACKUP RINGS MUST BE REPLACED PRIOR TO REASSEMBLY.
2. CYLINDER OF THE POWER PLATE, PISTON, AND O-RINGS MUST BE PRE-LUBED WITH SYSTEM HYDRAULIC FLUID PRIOR TO REASSEMBLY.
3. PISTON ASSEMBLY:
ASSEMBLE PISTON INTO POWER PLATE USING A SHOP PRESS. TAKE CARE NOT TO DAMAGE THE O-RINGS. VISUALLY ALIGN THE CENTER OF THE CUTOUTS IN THE PISTON WITH THE TORQUE PIN HOLES IN THE POWER PLATE.

CAUTION: THE DEPTH THE PISTON IS INSTALLED INTO THE POWER PLATE IS CRITICAL. THE SURFACE OF THE PISTON AT THE CUTOUTS MUST BE FLUSH TO 0.120" [3.05 mm] BELOW THE SURFACE OF THE POWER PLATE OR PISTON WILL COCK, RESULTING IN A COMPLETE LOSS OF BRAKING.
4. BEARING ASSEMBLY:
USING A SHOP PRESS, INSTALL ONE CONE ON THE SHAFT. BEARING MUST BE SEATED TIGHT AGAINST THE STOP. PRESS ONLY ON THE INNER RACE OF THE BEARING CONE, NOT ON THE ROLLERS. INSTALL THE STATIONARY AND ROTATING DISCS ON THE SHAFT. NOTE THE ORDER OF THE DISCS IN RELATIONSHIP TO THE ENDS OF THE SHAFT. PRESS THE OTHER CONE ONTO THE SHAFT OBSERVING THE PRECEDING CAUTIONS.
5. BRAKE ASSEMBLY:
INSTALL PARTS IN REVERSE ORDER OF DISASSEMBLY LEAVING THE SHAFT SEALS TO LAST. RELEASE THE BRAKE WITH 300 PSI [21 BAR] AND MEASURE THE TORQUE TO ROTATE THE SHAFT. THE FREE ROLLING TORQUE OF THE BRAKE SHAFT IS AN INDICATION OF BEARING SEATING AND FIT. THE ROLLING TORQUE MUST BE 20 IN-LB [2.3 Nm] MAXIMUM. IF IT DOES NOT MEET SPECIFICATION, CHECK THAT THE BEARINGS ARE WELL SEATED.
6. LIP SEAL ASSEMBLY:
AFTER THE BRAKE IS ASSEMBLED, INSTALL THE OIL SEALS WITH CAUTION NOT TO CUT THE SEAL LIPS ON THE SHAFT SPLINES. THE INNER BRAKE SHAFT SEALS ARE INSTALLED WITH TWIN LIPS FACING OUTWARD, AWAY FROM THE BRAKE. THE SINGLE LIP WILL FACE INWARD. COAT THE O.D. OF THE INNER BRAKE SHAFT SEALS WITH LOCTITE 515 PRIOR TO INSTALLATION. THE OUTER YOKE WIPER SEALS ARE TO BE INSTALLED WITH THE WIPER LIP FACING OUTWARD. SEE CUTAWAY VIEW FOR SEAL ORIENTATION DETAIL.

SERVICE KIT INFORMATION:

BEARING KIT: PK-1931 - INCLUDES INTERNAL SEALS, RETAINING RINGS, AND BEARINGS.

STACK KIT: PK-1736 - INCLUDES TORQUE PINS, PRIMARY DISC, STATIONARY DISCS, ROTATING DISCS, AND COMPRESSION SPRINGS.

O-RING KIT: PK-1790 - INCLUDES O-RINGS.

ITEM	PART	DESCRIPTION	QTY
1	37176	PRESSURE RELIEF VALVE	1
2	35588	RETAINING RING	2
3	80992	OIL SEAL	2
4	75413	SPLINED SHAFT	1
5	90118	TAPERED ROLLER BEARING (CONE)	2
6	90119	TAPERED ROLLER BEARING (CUP)	2
7	36384	COMPRESSION SPRING	18
8	36385	COMPRESSION SPRING	18
9	74863	SPRING RETAINER	1
10	94458	PAINTED HOUSING	1
11	74849	PRIMARY DISC	1
12	35553	HEX HEAD PLUG	2
13	87275	ROTATING DISC	5
14	74857	STATIONARY DISC	5
15	85236	PAINTED POWER PLATE	1
16	84580	SHIM	*
17	86049	SHIM	*
18	75676	SPACER	1
19	75418	WASHER	1
20	74923	HEX NUT	1
21	75414	RETAINING RING	1
22	85268	OIL SEAL	2
23	36673	PROTECTIVE PLUG	1
24	86935	GREASE FITTING	2
25	74847	O-RING	1
26	74943	PISTON	1
27	74843	O-RING	1
28	75247	TORQUE PIN	2
29	85075	O-RING	1
30	85593	O-RING	6
31	85606	HEX FLANGE BOLT	6
32	75970	CAUTION TAG	1

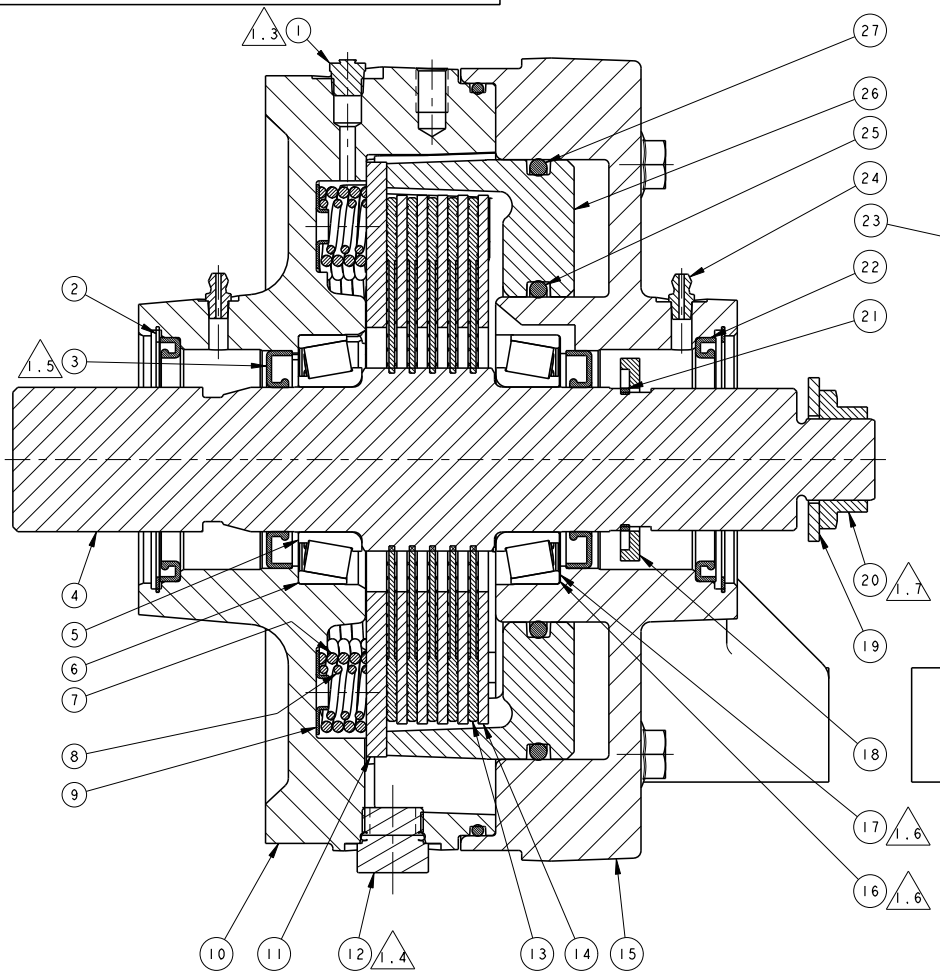

SECTION A-A

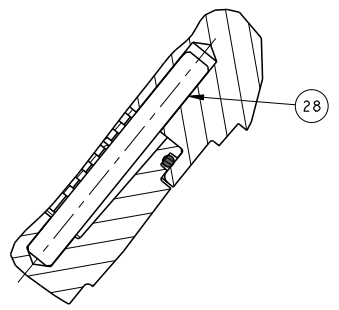
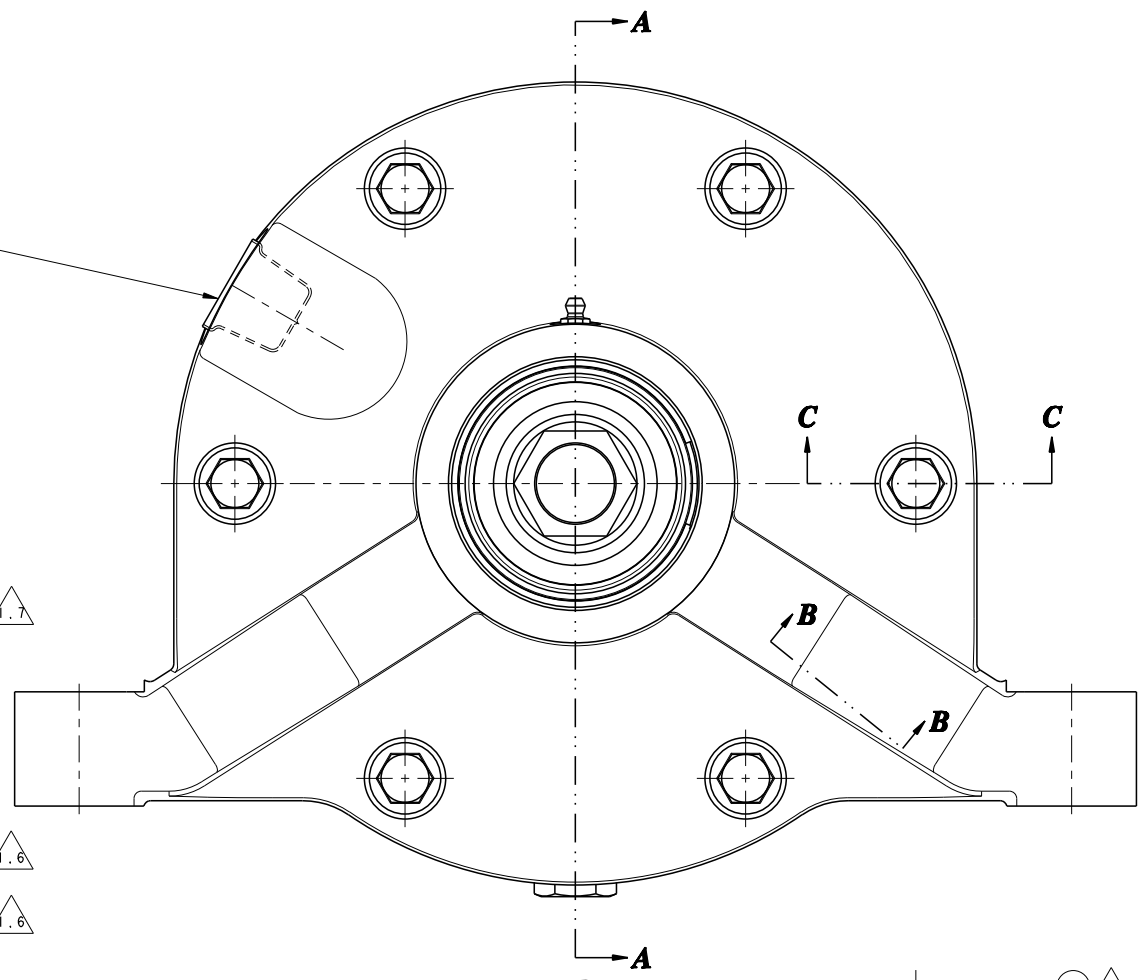

SECTION B-B

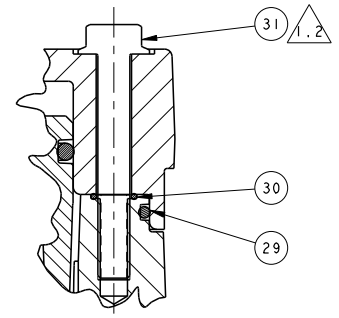

SECTION C-C

GENERAL ASSEMBLY VIEW

THIS DRAWING PROVIDES GENERAL GUIDELINES AND ASSEMBLY INFORMATION ON AUSCO MULTI-DISC BRAKES. CONFIGURATION OF BRAKES VARIES FROM MODEL TO MODEL. CONSULT YOUR BRAKES SERVICE NOTES, BILL OF MATERIAL, AND CUTAWAY VIEW FOR EXACT DETAILS.

