



# BRAKE NUMBER 101989 SERVICE NOTES

ECO 31962 REV G

THE MULTI DISC BRAKE WITH SERVICE IS A SPRING APPLIED BRAKE WITH AN INDEPENDENT SERVICE FEATURE. HYDRAULIC PRESSURE IS REQUIRED TO RELEASE OR "HOLD OFF" THE BRAKE. NORMAL OPERATION IS TO HAVE THE BRAKE PRESSURIZED IN THE RELEASED POSITION WITH THE VEHICLE HYDRAULIC SYSTEM RUNNING. ANY FUNCTION WHICH REDUCES THE HYDRAULIC SYSTEM PRESSURE BELOW THE RELEASE PRESSURE OF THE BRAKE WILL CAUSE THE BRAKE TO BE APPLIED. IN ADDITION, THE BRAKE MAY BE APPLIED VIA SEPERATE HYDRAULIC SYSTEM CONNECTED TO THE SERVICE BRAKE INLET. PRESSURE IN THIS CIRCUIT WILL APPLY THE BRAKE. THE BRAKE TORQUE WILL BE DIRECTLY PROPORTIONAL TO THE AMOUNT OF PRESSURE APPLIED. THE FAILSAFE PORTION OF THE BRAKE WILL NOT BE AFFECTED.

## CAUTION:

FOR CORRECT OPERATION, THE SERVICE HYDRAULIC PRESSURE MUST FALL TO ZERO TO ALLOW "FREE-RUNNING CONDITION." ANY BACK PRESSURE WILL RESULT IN A PARTIALLY APPLIED BRAKE. IN THIS CONDITION, VEHICLE MOTION MAY CAUSE PREMATURE LINING WEAR, WHICH MAY RESULT IN A HAZARDOUS CONDITION.

## INITIAL INSTALLATION INFORMATION:

1. ASSEMBLE BRAKE TO VEHICLE. SLIDE BRAKE OVER AXLE SPLINE, ALIGNING THE INTERNAL SPLINES OF THE BRAKE WITH THE SPLINES OF THE AXLE. POSITION BRAKE SO THAT THE BRAKE LINE FITTINGS ARE AT THE TOP OF THE BRAKE FOR BLEEDING PURPOSES.
2. PLACE THE MOUNTING BRACKETS ON THE INBOARD SIDE OF THE AXLE MOUNTING FLANGE. INSERT FOUR LUBRICATED 5/16-18 HEX HEAD BOLTS (GRADE 8) THROUGH THE MOUNTING BRACKETS, THROUGH THE AXLE MOUNTING FLANGE, AND INTO THE THREADED HOLES IN THE BRAKE. TORQUE HEX HEAD BOLTS TO 220-245 IN-LB (25-28 Nm).
3. WITH BRAKE IN POSITION, CONNECT SERVICE LINE WITH M10 X 1.0 BANJO BOLT. USE BRASS WASHERS ON BOTH SIDES OF BANJO BOLT FITTING FOR PROPER SEALING.
4. WITH BRAKE IN POSITION, CONNECT PARK INLET BRAKE LINE. PARK BRAKE INLET IS 7/16-20 UNF-2B O-RING BOSS PORT.
5. GREASE OUTBOARD SEALS BY INSTALLING GREASE INTO FRONT GREASE FITTING UNTIL IT RUNS OUT THE FRONT SHAFT SEAL. TURN HUB 1/4 TURN AND REPEAT GREASING THREE TIMES.
6. BLEED BRAKE TO ELIMINATE ANY AIR IN THE BRAKE LINES.
7. FOR WHEEL ASSEMBLY, FOLLOW VEHICLE MANUFACTURER'S INSTRUCTIONS.

## BRAKE DISASSEMBLY INFORMATION

1. REMOVE BRAKE FROM VEHICLE.
2. SPECIALIZED EQUIPMENT AND GAGING IS NEEDED TO PROPERLY REBUILD THE BRAKE. IF THE BRAKE IS WORN OR DAMAGED, REPLACE BRAKE.

### OIL FILL PROCEDURE:

BRAKE IS PRE-FILLED WITH AW68 OIL. IF OIL IS REMOVED FOR ANY REASON, REFILL WITH 250±10mL OF AW68 OIL. USE PORT ON REAR FACE OF BRAKE. TIGHTEN PLUG WHEN FINISHED.

### PRESSED STUD REPLACEMENT PROCEDURE

NOTE: THIS PROCEDURE IS ONLY FOR BRAKES WITH A 2 PIECE FLANGED HUB.

1. REMOVE (4) 3/8-16 BOLTS HOLDING FLANGE TO MAIN HUB.
2. REMOVE FLANGE.
3. PRESS OUT AND REPLACE STUDS AS NEEDED.
4. REPLACE FLANGE O-RING AND REGREASE.
5. BEFORE REINSTALLING FLANGE VERIFY THAT BOTH MOUNTING SURFACES AND INSIDE OF HUB IS CLEAN AND FREE OF DIRT AND DEBRIS.
6. REINSTALL FLANGE AND TIGHTEN 3/8-16 BOLTS TO 33-36 FT-LBF [45-49 Nm].

### SERVICE KIT INFORMATION:

NOTE: FOR 2 PIECE HUB ONLY

STUD KIT: PK.2686 - INCLUDES: PRESS FIT STUDS AND O-RING

**PRO/E**



## AUSCO BRAKE NO. 101989 PARTS LIST

ECO 31962 REV G

ITEM	PART	DESCRIPTION	QTY
1	101923	HEX HEAD BOLT	6
2	73464	WASHER	6
3	36359	COMPRESSION SPRING	18
4	32201	O-RING	6
5	26930	PROTECTIVE PLUG	1
6	92573	BLEEDER CAP	2
7	33425	BLEEDER SCREW	2
8	101871	PRIMARY DISC	1
9	101868	SECONDARY DISC	1
10	75072	STATIONARY DISC	3
11	90730	ROTATING DISC	3
12	92572	GREASE FITTING CAP	1
13	86935	GREASE FITTING	1
14	106954	WHEEL STUD	4
15	92351	OIL SEAL	1
16	106953	HEX FLANGE BOLT	4
17	106688	HUB	1
18	106738	O-RING	1
19	92350	OIL SEAL	1
20	106686	FLANGE-4 BOLT	1
21	101990	HOUSING	1
22	92725	TAPERED ROLLER BEARING (CONE)	1
23	92724	TAPERED ROLLER BEARING (CUP)	1
24	101891	O-RING	1
25	105404	PISTON	1
26	92563	HEX HEAD O-RING BOSS PLUG	2
27	101960	O-RING	1
28	105405	POWER PLATE	1
29	91930	O-RING	2
30	101877	SERVICE PISTON	1
31	89793	O-RING	1
32	92870	BALL BEARING	1
33	92547	O-RING	1
34	90767	HEX BOLT	4
35	92402	OIL SEAL	1
36	90725	MOUNTING BRACKET	2
37	93665	RETAINING RING	1
38	93754.03	THRUST WASHER	*
39	93754.04	THRUST WASHER	*
40	93754.05	THRUST WASHER	*
41	93664	C-RING	1
42	28435	PROTECTIVE PLUG	1
43	81057	CONNECTOR TUBE	1
44	81213	BACKUP RING	2
45	30552	O-RING	2
46	95250	PIPE PLUG	1
47	74688	TORQUE PIN	4
48	93025	COMPRESSION SPRING	2

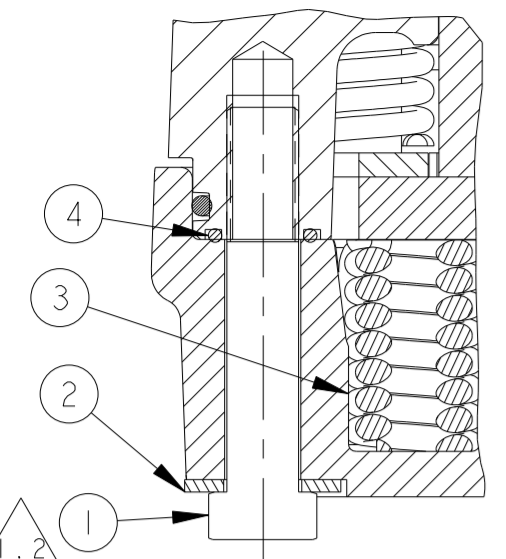

**SECTION B-B**

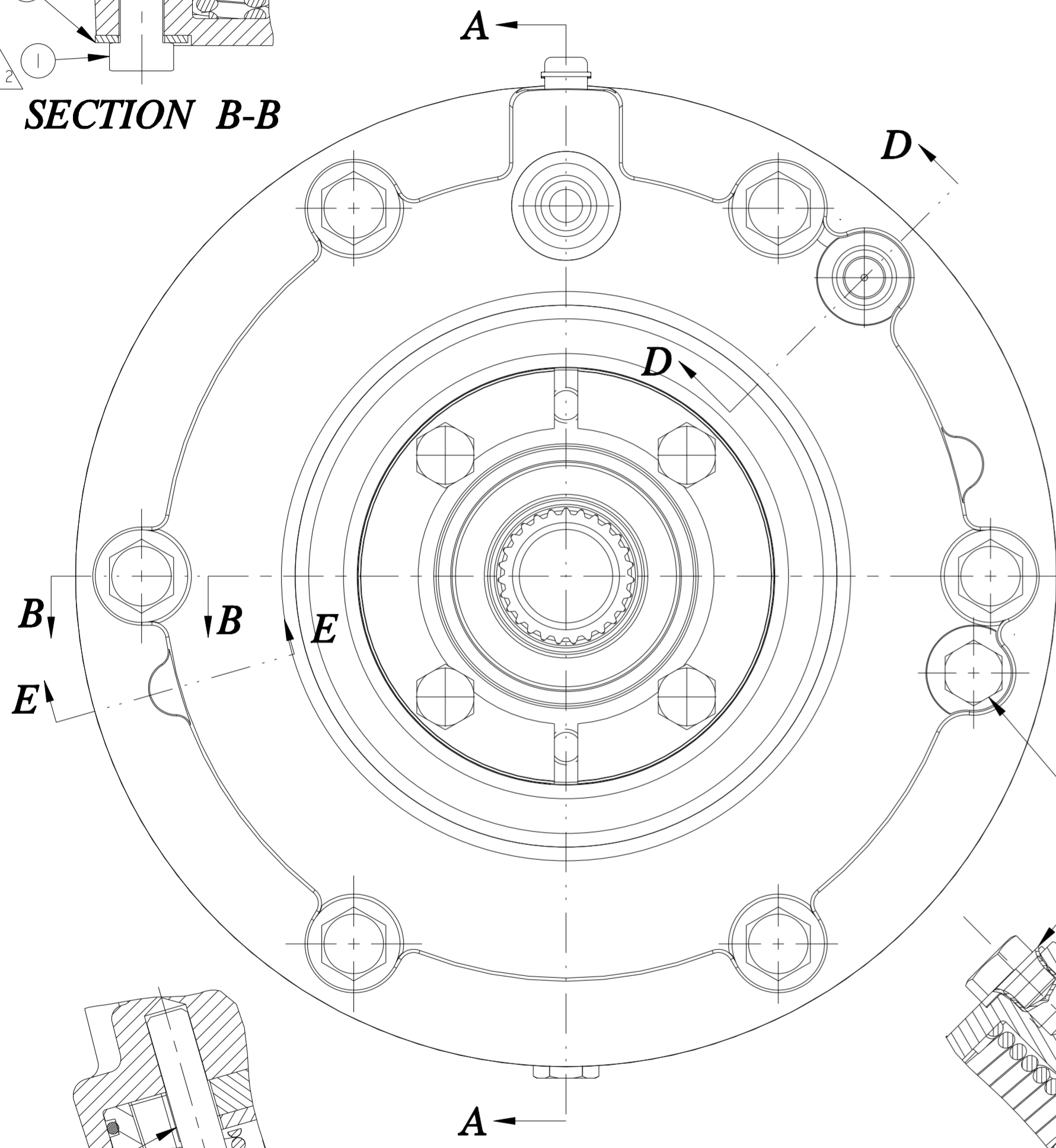

**SECTION E-E**

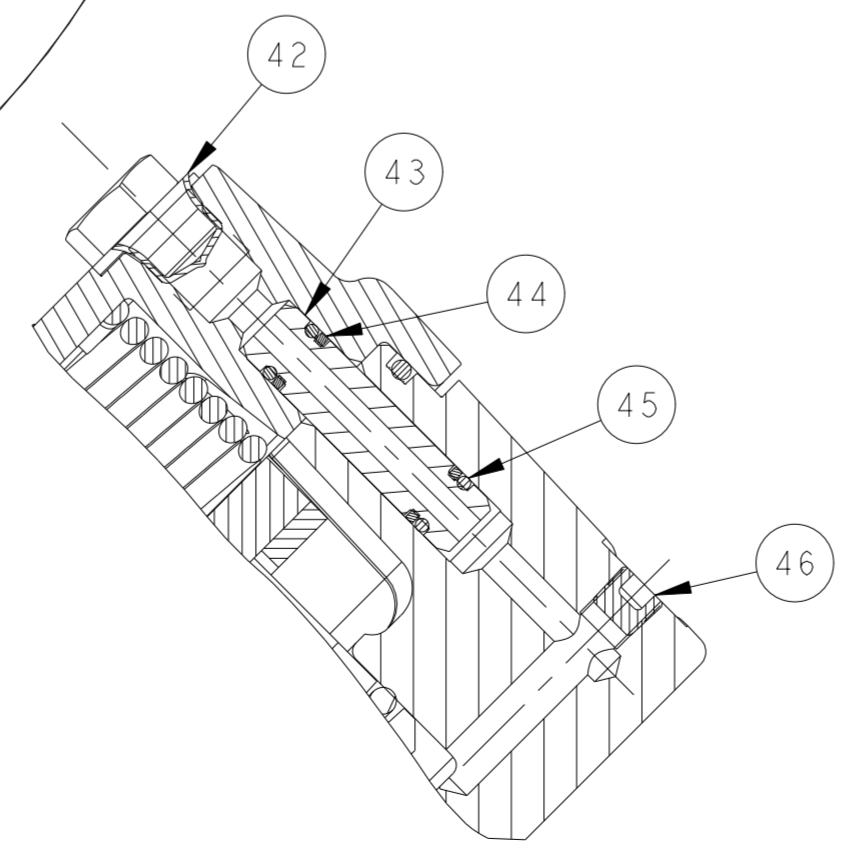
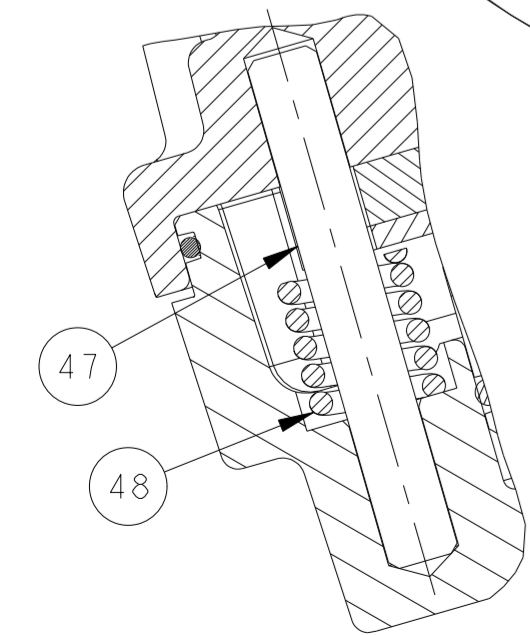

**SECTION D-D**

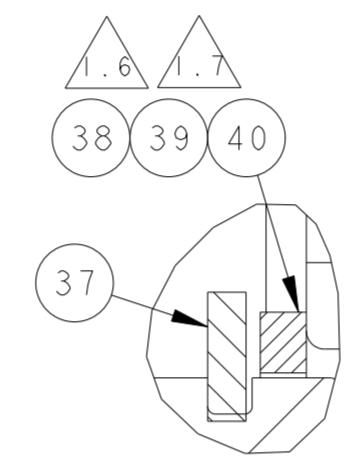

**DETAIL F**  
**SCALE 4.000**

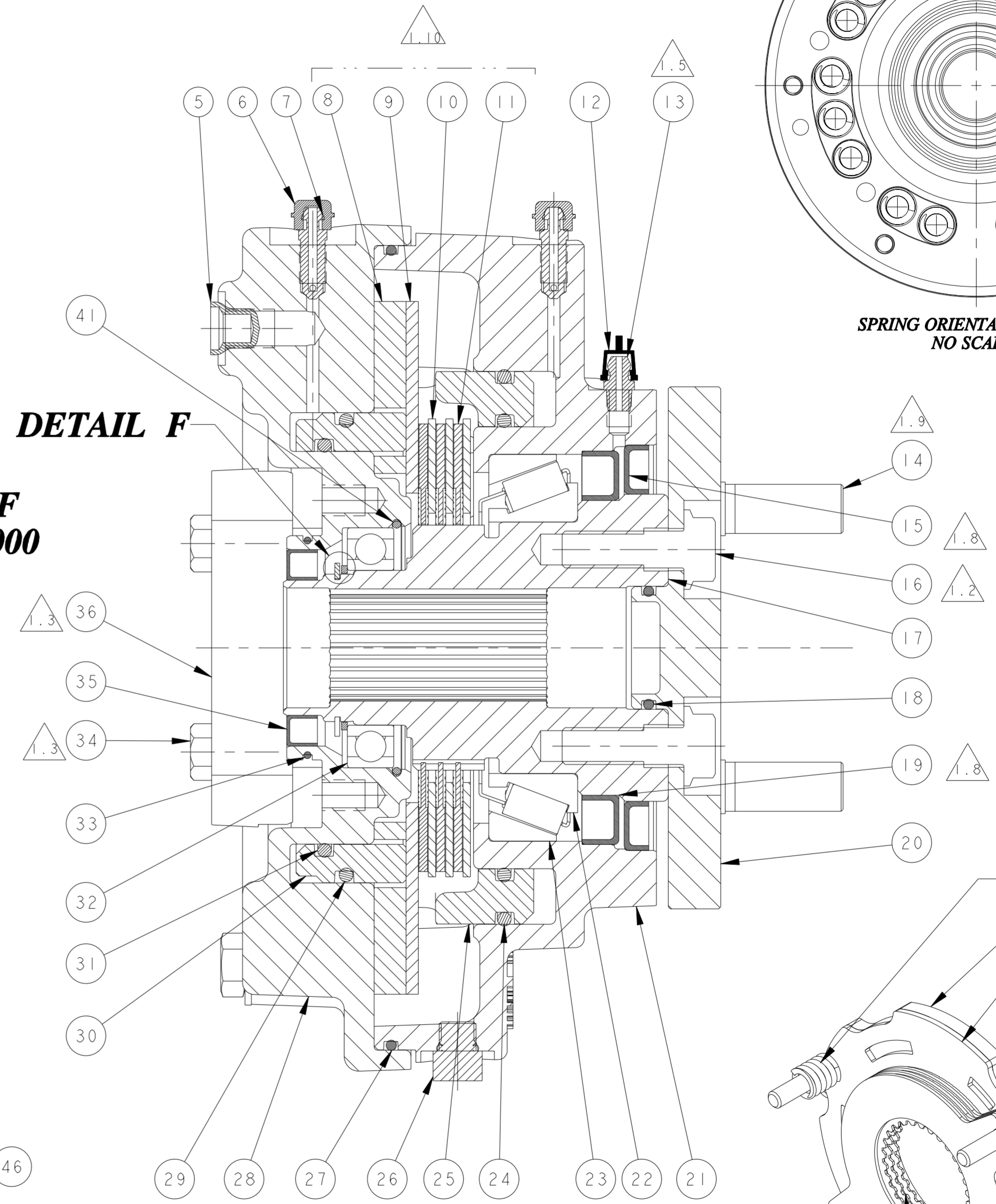

**SECTION A-A**

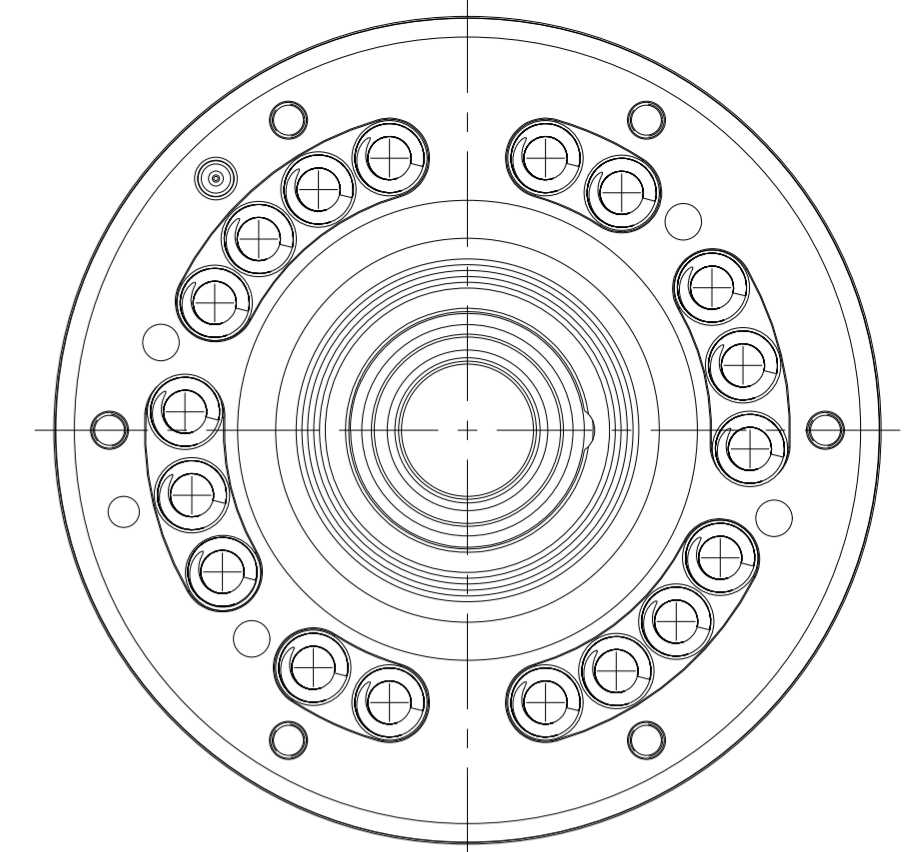

**SPRING ORIENTATION VIEW**  
**NO SCALE**

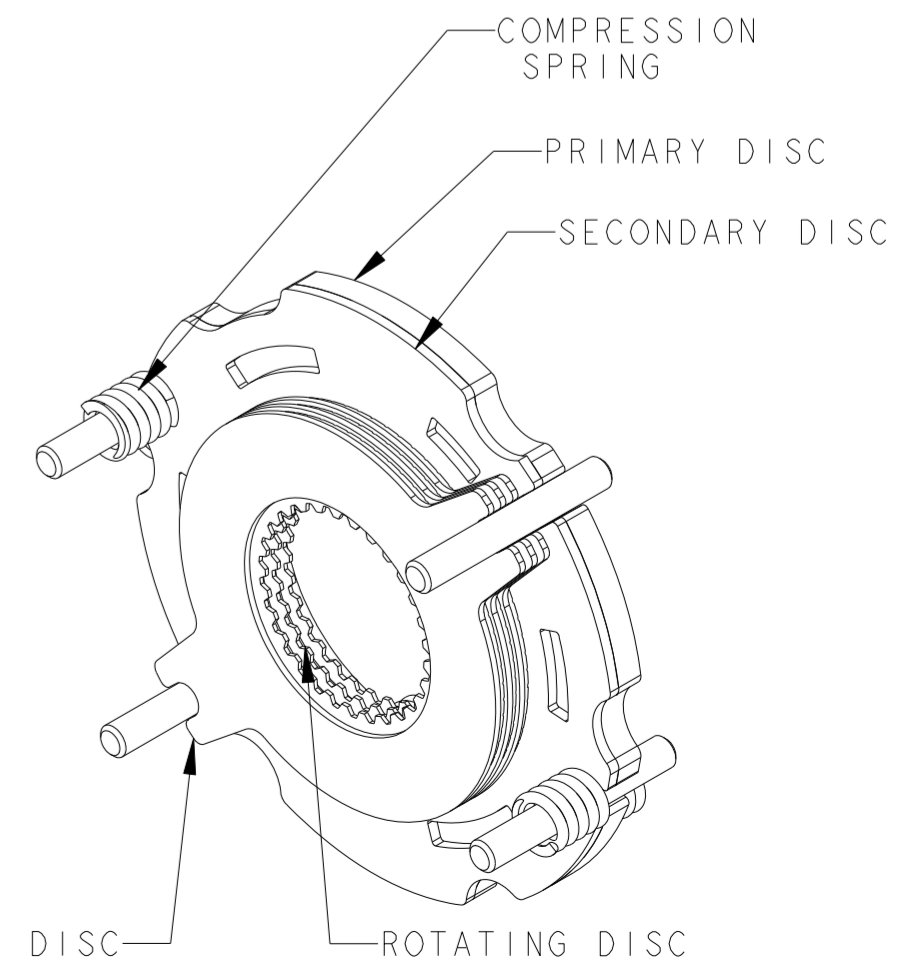

**DISC STACK ORIENTATION VIEW**