



# BRAKE NUMBER 76928 SERVICE NOTES

ECO 32002 REV G

THE MULTI-DISC BRAKE IS A SPRING-APPLIED, HYDRAULICALLY RELEASED BRAKE. HYDRAULIC PRESSURE IS REQUIRED TO RELEASE OR "HOLD OFF" THE BRAKE. NORMAL OPERATION IS TO HAVE THE BRAKE PRESSURIZED IN THE RELEASED POSITION WITH THE VEHICLE HYDRAULIC SYSTEM RUNNING. ANY FUNCTION WHICH REDUCES THE HYDRAULIC SYSTEM BELOW THE RELEASE PRESSURE OF THE BRAKE WILL CAUSE THE BRAKE TO BE APPLIED.

## CAUTION:

FOR CORRECT OPERATION, HYDRAULIC PRESSURE TO THE BRAKE MUST FALL TO ZERO PSI. ANY RESIDUAL BACK PRESSURE APPLIED TO THE BRAKE WILL DEGRADE FUNCTION AND MAY RESULT IN A HAZARDOUS CONDITION.

## INSTALLATION INFORMATION:

1. ASSEMBLE BRAKE BETWEEN MOTOR AND GEARBOX. PLACE MOUNTING GASKETS ON THE MOUNTING FACES BEFORE ASSEMBLY. IF NEEDED, BRAKE SHAFT CAN BE ROTATED BY APPLYING HYDRAULIC PRESSURE TO THE PISTON INLET PORT.
2. INSERT FOUR LUBRICATED  $\varnothing 1/2$ " BOLTS (GRADE 5) THROUGH THE BRAKE, THE GASKET AND INTO THE THREADED HOLES IN THE GEAR REDUCER. MAKE SURE THAT THE BOLTS ARE NOT TOO LONG, SO THEY DO NOT BOTTOM OUT IN THE THREADED HOLES OF THE GEAR REDUCER.
3. TO PREVENT BINDING, RUN THE BOLTS IN ALTERNATELY UNTIL SNUG. TORQUE BOLTS TO 55-65 FT-LBS [75-88 Nm].  
NOTE: THE SHAFTS MUST SLIDE TOGETHER FREELY. DO NOT USE THE BOLTS TO FORCE THEM TOGETHER.
4. MOUNT HYDRAULIC MOTOR WITH TWO UNLUBRICATED  $\varnothing 7/16$ " BOLTS (GRADE 5) THROUGH THE FLANGE AND GASKET INTO BRAKE. NOTE THE MAX FULL THREAD IN BRAKE. TORQUE BOLTS TO 50-60 FT-LBS [68-81 Nm].

ALTERNATE MOUNTING OF MOTOR WITH TWO LUBRICATED  $\varnothing 1/2$ " BOLTS (GRADE 5) THROUGH THE FLANGE AND GASKET INTO BRAKE. NOTE THE MAX FULL THREAD IN BRAKE. TORQUE BOLTS TO 55-65 FT-LBS [75-88 Nm].

5. WITH MOTOR AND BRAKE BOLTED TOGETHER INTO POSITION, CONNECT INLET HYDRAULIC LINE. BRAKE INLET IS 1/4" LINE STRAIGHT THREAD O-RING BOSS (7/16-20 UNF).

## BRAKE DISASSEMBLY INFORMATION:

1. DISASSEMBLE IN THE FOLLOWING ORDER: BOLTS (ALTERNATELY), POWER PLATE, GASKET, STATIONARY DISCS, ROTATING DISCS, PRIMARY DISC, TORQUE PINS, COMPRESSION SPRINGS, AND SPRING RETAINER.
2. FURTHER DISASSEMBLY IS NOT RECOMMENDED AND SHOULD NOT BE ATTEMPTED UNLESS NECESSARY TO REPLACE THE BEARING, THE SEAL, OR THE SHAFT.  
NOTE: IF THE BEARING AND SEAL ARE REMOVED FOR ANY REASON, BOTH MUST BE REPLACED.
  - 2a. REMOVE SNAP RINGS AS NEEDED.
  - 2b. SEAL CAN BE REMOVED BY PRYING IT OUT WITH AN APPROPRIATE TOOL. TAKE CARE NOT TO DAMAGE THE BORE.
  - 2c. SHAFT CAN BE REMOVED BY PRESSING IT OUT WITH A SHOP PRESS.
3. REMOVE THE PISTON FROM THE POWER PLATE BY INTRODUCING LOW PRESSURE AIR (15 PSI [1 BAR]) INTO THE HYDRAULIC INLET. MAKE SURE THE PISTON IS DIRECTED AWAY FROM THE OPERATOR. DO NOT REMOVE O-RINGS AND BACKUP RINGS FROM THE O.D. AND I.D. GROOVES OF THE PISTON UNLESS REPLACEMENT IS NECESSARY, BECAUSE THEY WILL BE DAMAGED.

## ASSEMBLY INFORMATION:

IMPORTANT: THERE MAY BE MORE PARTS IN A SERVICE KIT THAN YOUR BRAKE REQUIRES. CHECK THE PARTS LIST CAREFULLY FOR THE EXACT QUANTITY. SPACE THE SPRINGS AS SHOWN ON THE SPRING ORIENTATION VIEW.

USE THE REVERSE OF THE DISASSEMBLY PROCEDURE WITH THE FOLLOWING NOTES AND ADDITIONS:

1. WORN AND DAMAGED O-RINGS AND BACKUP RINGS MUST BE REPLACED PRIOR TO RE-ASSEMBLY.
2. LUBRICATE THE PISTON BORE OF THE POWER PLATE, THE PISTON, THE O-RINGS, AND BACKUP RINGS WITH SYSTEM HYDRAULIC FLUID PRIOR TO RE-ASSEMBLY.
3. PISTON ASSEMBLY:  
ASSEMBLE PISTON INTO POWER PLATE USING A SHOP PRESS. TAKE CARE NOT TO DAMAGE THE O-RING OR TEFLON BACKUP RINGS. VISUALLY ALIGN THE CENTER OF THE CUTOUTS IN THE PISTON WITH THE TORQUE PIN HOLES IN THE POWER PLATE.  
CAUTION:  
THE DEPTH THE PISTON IS INSTALLED INTO THE POWER PLATE IS CRITICAL. THE SURFACE OF THE PISTON AT THE CUTOUTS MUST BE FLUSH TO 0.120 [3,05 mm] BELOW THE SURFACE OF THE POWER PLATE, OR PISTON MAY COCK RESULTING IN A COMPLETE LOSS OF BRAKING.
4. BEARING ASSEMBLY:  
USE A SHOP PRESS TO PRESS THE BEARING ONTO THE SHAFT. PRESS ONLY ON THE INNER RACE OF THE BEARING. BEARING IS A SLIP FIT TO THE HOUSING.
5. LIP SEAL ASSEMBLY:  
LIP OF SEAL MUST FACE TOWARD THE BEARING. SEE CUTAWAY VIEW FOR SEAL ORIENTATION DETAIL.
6. ROTATING, STATIONARY, AND PRIMARY DISC ASSEMBLY:  
ROTATING DISC MUST BE CLEAN & DRY. THE LINING MATERIAL AND MATING SURFACES OF THE STATIONARY DISCS MUST BE THOROUGHLY CLEAN AND FREE FROM DEBRIS. WORN OR SCARRED ROTATING DISCS MUST BE REPLACED.
7. INSTALL BOLTS IN THE POWER PLATE. TIGHTEN SEQUENTIALLY ONE TURN AT A TIME UNTIL POWER PLATE IS PROPERLY SEATED. TORQUE BOLTS TO 80-90 FT-LBS [108-122 Nm].

## OIL FILL PROCEDURE:

UNSCREW THE TOP OIL FILL PLUG AND ADD DTE 26 OIL TO THE APPROPRIATE LEVEL.

HORIZONTAL POSITION: 150 mL  
VERTICAL POSITION: 300 mL

## SERVICE KIT INFORMATION:

- BEARING KIT: PK - 933 - INCLUDES SEALS, RETAINING RINGS, AND BEARINGS.
- STACK KIT: PK - 1370 - INCLUDES TORQUE PINS, PRIMARY, STATIONARY, ROTATING DISCS AND COMPRESSION SPRINGS.
- O-RING KIT: PK - 1368 - INCLUDES O-RINGS, BACKUP RINGS, AND INTERNAL GASKET.
- GASKET KIT: PK - 1398 - INCLUDES EXTERIOR GASKET(S).

ITEM	PART	DESCRIPTION	QTY
1	75731	HOUSING	1
2	36359	COMPRESSION SPRING	16
3	36367	SPRING RETAINER	1
4	36342	LIP SEAL	1
5	75728	SPLINED SHAFT	1
6	28284	BALL BEARING	2
7	28285	RETAINING RING	2
8	28427	GASKET	1
9	75071	PRIMARY DISC	1
10	75072	STATIONARY DISC	7
11	74996	DISC ROTATING	6
12	75395	TEFLON TAPERED PLUG	2
13	73448	GASKET	1
14	32833	BACKUP RING	1
15	36701	O-RING	1
16	29035	SCREW BLEEDER	1
17	37323	POWER PLATE	1
18	75724	PISTON	1
19	27967	BACKUP RING	1
20	27808	O-RING	1
21	30468	GASKET	1
22	31218	FLANGE HEX SCREW	2
23	28435	PLUG PROTECTIVE	1
24	28811	HEX PLUG	1
25	27948	TORQUE PIN	2
26	75970	CAUTION TAG	1

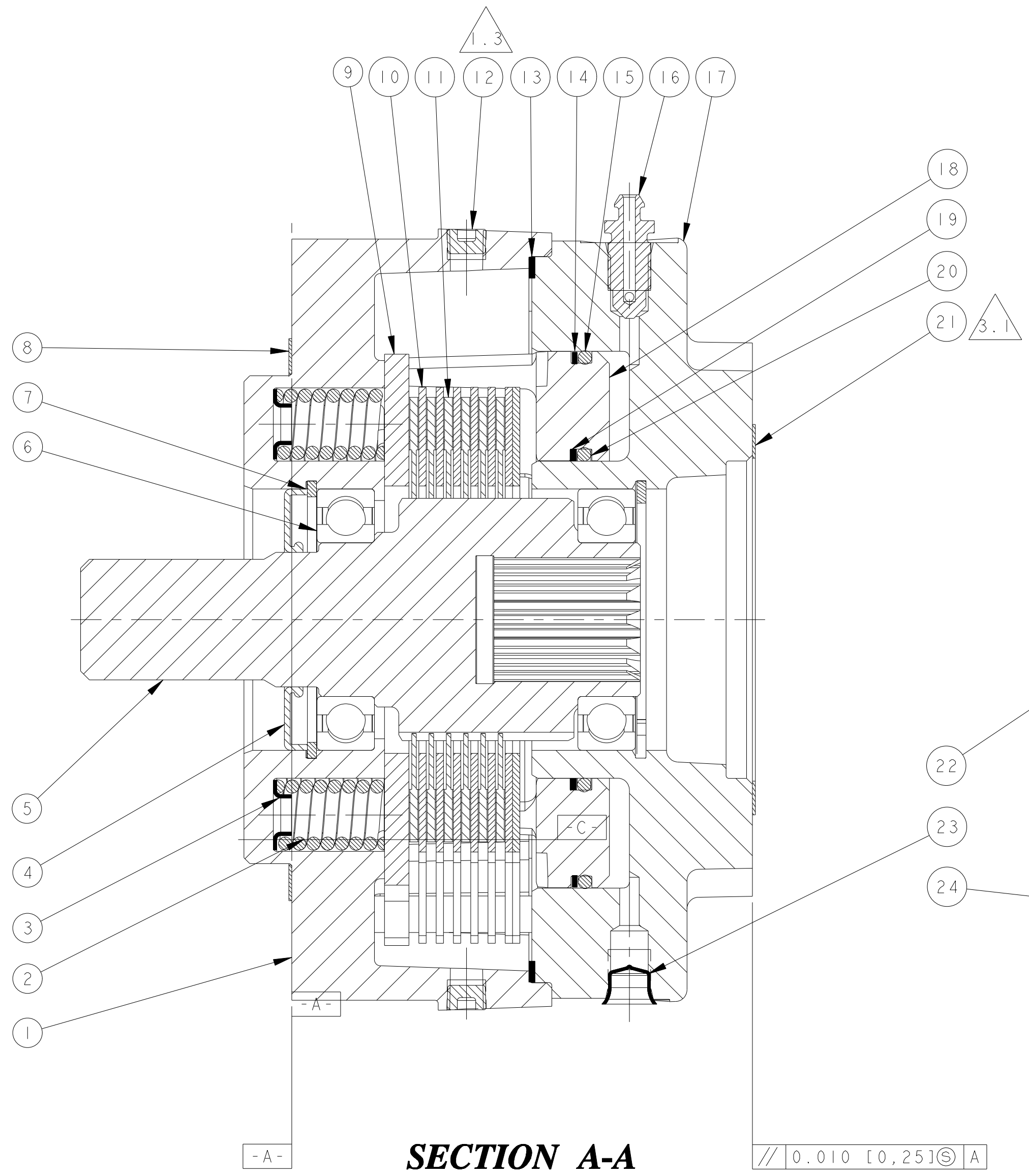

**SECTION A-A**

(E8)

/// 0.010 [0,25] © A

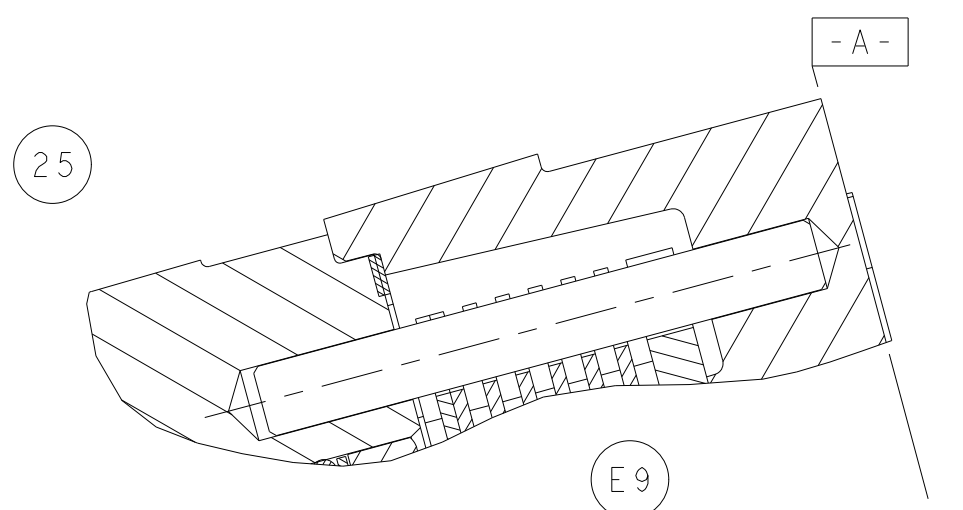
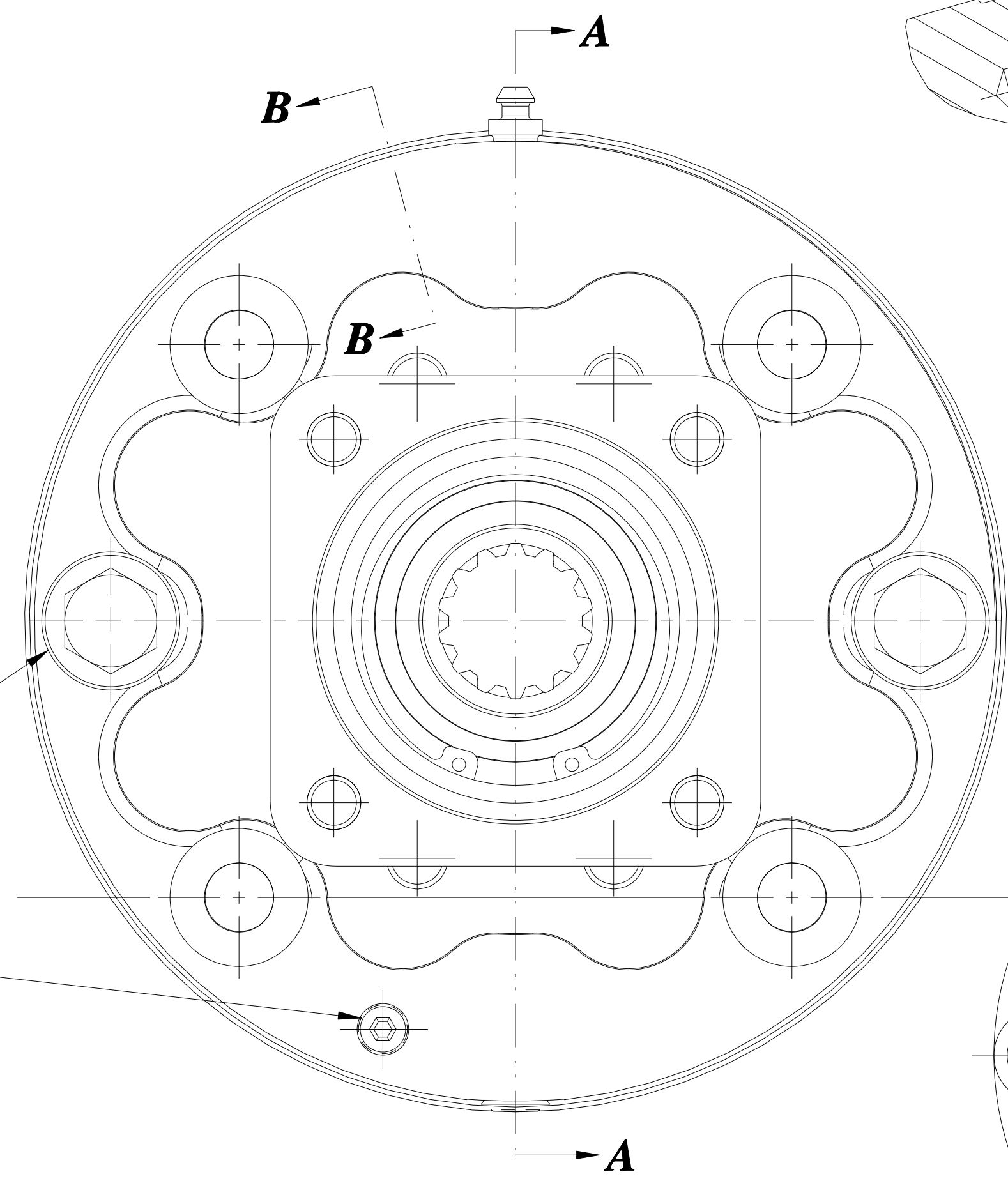

**SECTION B-B**

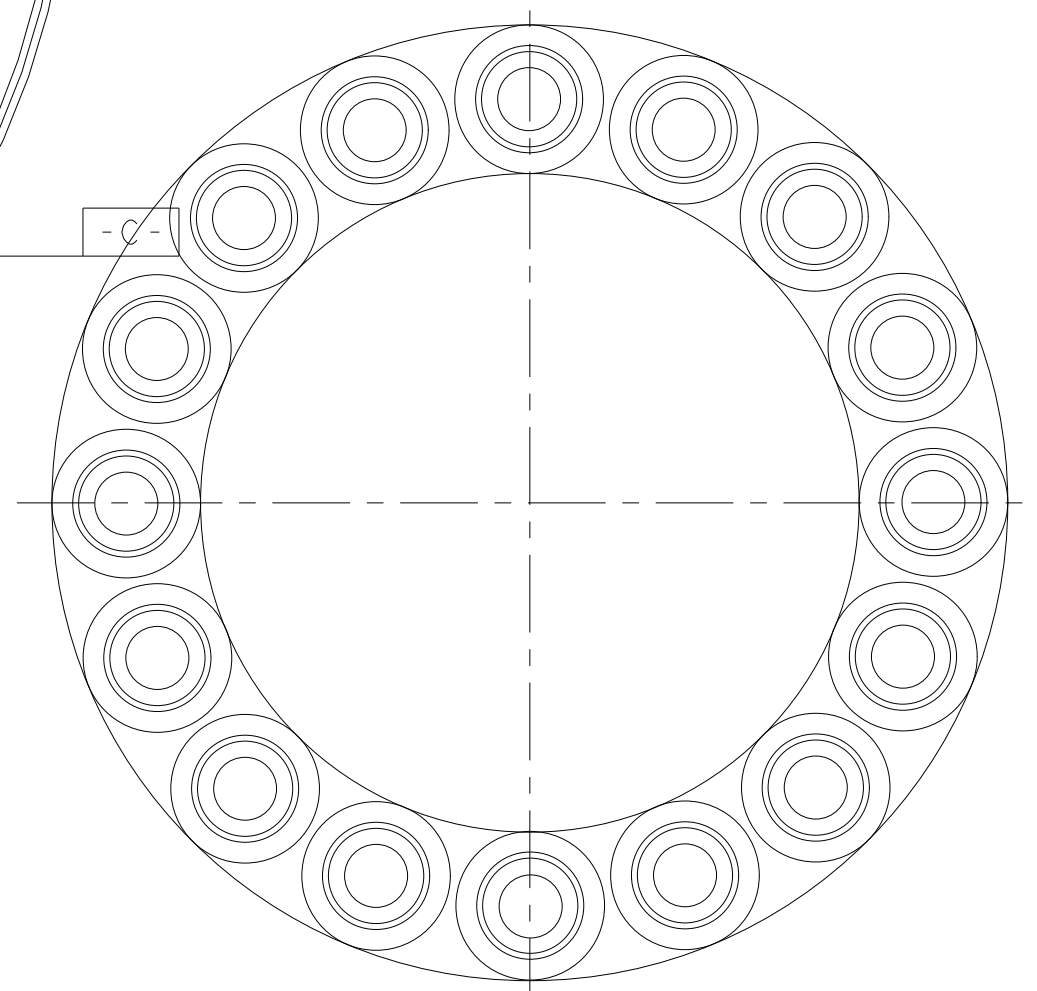

**SPRING ORIENTATION**  
NO SCALE

3.2

NOTE: THIS DRAWING PROVIDES GENERAL GUIDELINES AND ASSEMBLY INFORMATION ON AUSCO MULTI-DISC BRAKES. CONFIGURATION OF BRAKES VARIES FROM MODEL TO MODEL. CONSULT YOUR BRAKES SERVICE NOTES, BILL OF MATERIAL, AND CUTAWAY VIEW FOR EXACT DETAILS.

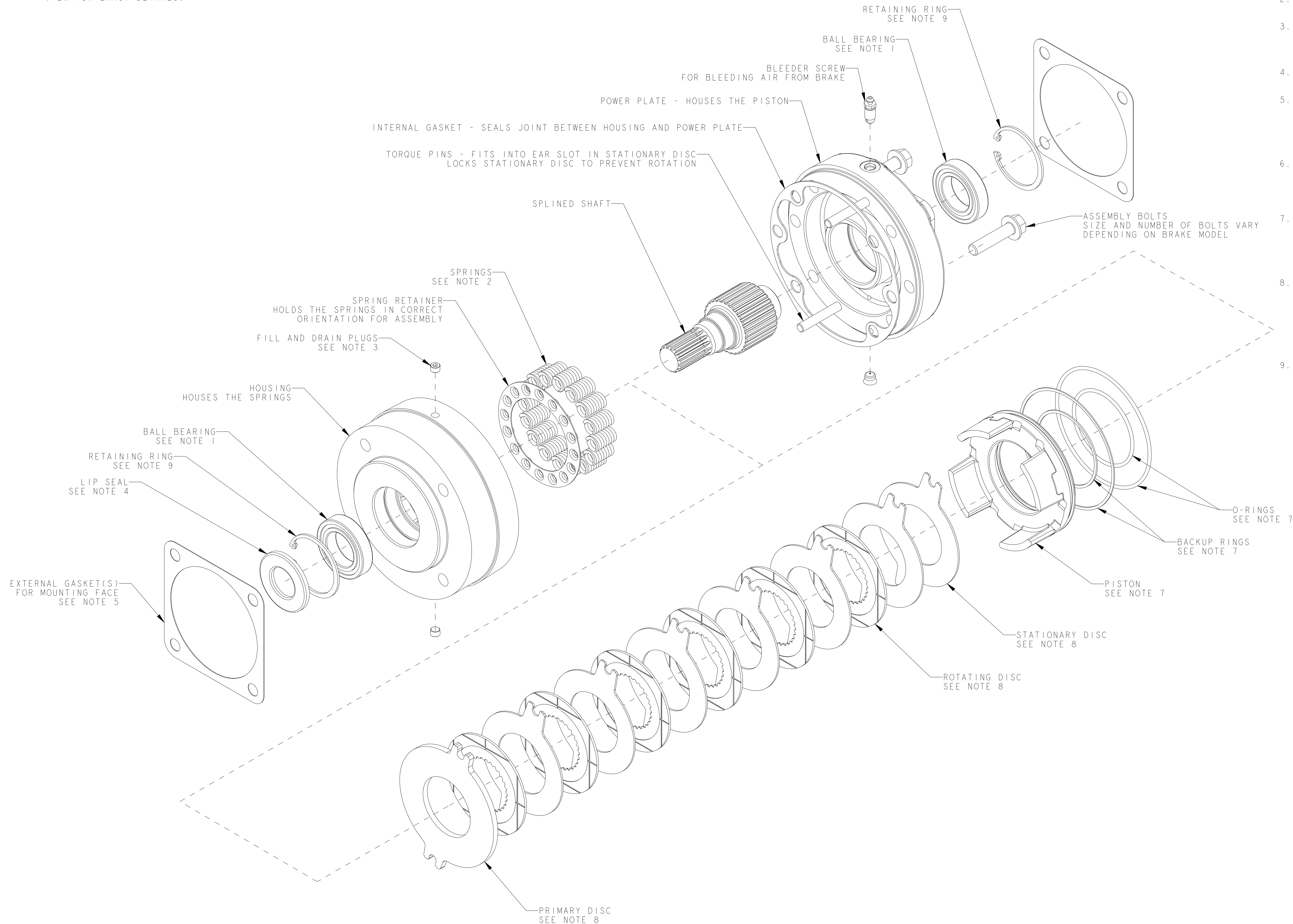

- NOTES:
1. BALL BEARING CONFIGURATION VARIES. SOME BRAKES DO NOT HAVE A BEARING, SOME ONLY HAVE ONE BEARING. SEE CUTAWAY VIEW FOR DETAILS. BEARINGS ARE NORMALLY PRESSED ONTO THE SHAFT AND SLIP FIT TO THE HOUSING. WHENEVER YOU PRESS A BEARING ONTO A SHAFT, ALWAYS PRESS ON THE INNER RACE ONLY.
  2. SPRING DESIGN, CONFIGURATION, AND ORIENTATION VARIES. SEE SPRING ORIENTATION VIEW FOR DETAILS.
  3. FILL AND DRAIN PLUGS ARE AVAILABLE ONLY ON WET BRAKE MODELS. USE THESE PLUGS FOR FILLING BRAKE CAVITY WITH OIL. SEE SERVICE NOTES FOR INSTRUCTIONS ON OIL FILL PROCEDURES.
  4. LIP SEAL POSITION AND ORIENTATION VARIES. SEE CUTAWAY VIEW AND SERVICE NOTES FOR DETAILS.
  5. MOUNTING GASKETS ARE USED FOR SEALING BETWEEN THE BRAKE AND MATING COMPONENTS. MANY APPLICATIONS USE AN O-RING TO SEAL THIS FACE INSTEAD OF USING THE GASKET. CONSULT THE EQUIPMENT MANUFACTURER IF YOU ARE IN QUESTION AS TO YOUR CONFIGURATION.
  6. PRESSURE RELIEF VALVE. SOME DRY BRAKES USE A LOW PRESSURE RELIEF VALVE TO LET OIL OUT OF THE BRAKE IN THE EVENT OF LEAKAGE. IN SOME APPLICATIONS THE PORT FOR THIS VALVE IS PLUGGED OR DOES NOT EXIST. SEE CUTAWAY VIEW FOR DETAIL.
  7. O-RING AND BACKUP RING ORIENTATION IS CRITICAL. O-RING SHOULD ALWAYS BE IN CONTACT WITH THE PRESSURIZED OIL. THE BACKUP RING SUPPORTS THE O-RING AT HIGH PRESSURE. BACKUP RING MUST BE PLACED BEHIND THE O-RING IN THE O-RING GROOVE, ON THE SIDE OPPOSITE OF THE PRESSURIZED OIL.
  8. PRIMARY DISC IS ALWAYS THE DISC DIRECTLY CONTACTING THE SPRINGS. TORQUE PINS GO THROUGH THE SLOTS IN THE STATIONARY DISCS AND PRIMARY DISC. THE NUMBER OF DISCS AND THEIR ORIENTATION VARIES. SEE CUTAWAY VIEW FOR DETAILS. IT IS CRITICAL THAT THE STACK IS CONFIGURED CORRECTLY FOR YOUR APPLICATION OR BRAKE FUNCTION WILL BE COMPROMISED.
  9. SNAP RING CONFIGURATION VARIES. SEE CUTAWAY VIEW FOR DETAILS.