



# BRAKE NUMBER 84490 SERVICE NOTES

ECO 31870 REV K

THE FAILSAFE BRAKE IS SPRING LOADED TO APPLY THE BRAKE AND HYDRAULIC PRESSURE IS REQUIRED TO RELEASE OR "HOLD OFF" THE BRAKE. NORMAL OPERATION IS TO HAVE THE BRAKE PRESSURIZED WITH THE VEHICLE HYDRAULIC SYSTEM RUNNING. ANY FUNCTION WHICH REDUCES THE HYDRAULIC SYSTEM PRESSURE BELOW THE RELEASE PRESSURE OF THE BRAKE WILL CAUSE THE BRAKE TO BE APPLIED.

## INSTALLATION INFORMATION:

1. REMOVE NUT AND WASHER FROM THE SHAFT.
2. INSTALL YOKE, WASHER AND NUT. TORQUE NUT TO 275-325 FT-LBS [373-441 Nm].
3. MOVE BRAKE INTO POSITION, ALIGN MOUNTING BOLT HOLES, AND INSERT FOUR NON-LUBRICATED 5/8 INCH BOLTS THROUGH HOLES IN EACH MOUNTING FOOT. TORQUE THE BOLTS AS FOLLOWS:  
FOR GRADE 5 BOLTS: 150-165 FT-LBS [203-224 Nm]  
FOR GRADE 8 BOLTS: 210-235 FT-LBS [285-319 Nm]
4. SLIDE YOKE OVER SHAFT.
5. CONNECT VEHICLE DRIVELINE TO BRAKE YOKES.
6. CONNECT HYDRAULIC SUPPLY LINE TO POWER PLATE INLET. INLET PORT IS 1 1/16-12 UN THREAD, O-RING BOSS PORT PER SAE J1926 (3/4" TUBE).
7. OIL FILL PROCEDURE:  
REMOVE FILL LEVEL PLUG FROM SIDE OF BRAKE. FILL BRAKE CAVITY WITH ESSO HYDRAULIC 56, EXXON HYDRAULIC 560, OR MOBIL 424 OIL UNTIL OIL RUNS OUT OF PORT. REPLACE PLUG AND TIGHTEN.

## BRAKE DISASSEMBLY INFORMATION:

1. REMOVE BRAKE FROM MOUNTING POSITION AND REMOVE YOKES.
2. POSITION BRAKE WITH POWER PLATE UP (THE SIDE WITH MOUNTING FEET).
3. REMOVE ASSEMBLY BOLTS ALTERNATELY KEEPING POWER PLATE PARALLEL TO THE HOUSING TO PREVENT DAMAGE TO BEARINGS. USE EXTREME CAUTION: SPRINGS CAN CAUSE POWER PLATE ASSEMBLY TO POP OFF HOUSING.
4. AFTER THE ASSEMBLY BOLTS HAVE BEEN REMOVED, REMOVE POWER PLATE ASSEMBLY FROM BRAKE.
5. REMOVE SHAFT AND DISC STACK FROM THE BRAKE. IF THE STACK IS TO BE SERVICED USE A SHOP PRESS TO REMOVE THE BEARING CONES FROM SHAFT.
6. REMOVE PRIMARY DISC, SPRINGS, AND SPRING RETAINER FROM HOUSING SPRING POCKET.
7. REMOVE PISTON FROM POWER PLATE BY INTRODUCING LOW-PRESSURE AIR (15 PSI [1 BAR]) INTO HYDRAULIC INLET. MAKE SURE THE PISTON IS DIRECTED AWAY FROM THE OPERATOR. REMOVE O-RINGS FROM THE O.D. AND I.D. OF THE GROOVE OF THE PISTON.  
NOTE: IF THE BEARINGS AND/OR SEALS ARE REMOVED, BOTH MUST BE REPLACED. SEAL CAN BE REMOVED BY PRYING IT OUT WITH AN APPROPRIATE TOOL. CARE MUST BE TAKEN NOT TO DAMAGE THE BORE.

## ASSEMBLY INFORMATION:

IMPORTANT: THERE MAY BE MORE PARTS IN A SERVICE KIT THAN YOUR BRAKE REQUIRES. CHECK THE PARTS LIST CAREFULLY FOR THE EXACT QUANTITY. SPACE THE SPRINGS AS SHOWN ON THE SPRING ORIENTATION.

USE THE REVERSE OF THE DISASSEMBLY PROCEDURE WITH THE FOLLOWING NOTES AND ADDITIONS:

1. WORN AND DAMAGED O-RINGS MUST BE REPLACED PRIOR TO REASSEMBLY.
2. PISTON BORE IN POWER PLATE, PISTON, AND O-RINGS MUST BE PRE-LUBED WITH SYSTEM HYDRAULIC FLUID PRIOR TO ASSEMBLY.
3. PISTON ASSEMBLY:  
ASSEMBLE PISTON INTO POWER PLATE USING A SHOP PRESS. TAKE CARE NOT TO DAMAGE THE O-RINGS. VISUALLY ALIGN THE CENTER OF THE CUTOUS IN THE PISTON WITH THE TORQUE PIN HOLES IN THE POWER PLATE. CAUTION: THE DEPTH THE PISTON IS INSTALLED INTO THE POWER PLATE IS CRITICAL. THE SURFACE OF THE PISTON AT THE CUTOUS MUST BE FLUSH TO 0.120 [3.05mm] BELOW THE SURFACE OF THE POWER PLATE OR PISTON WILL COCK RESULTING IN A COMPLETE LOSS OF BRAKING.
4. BEARING ASSEMBLY:  
USING A SHOP PRESS, INSTALL ONE CONE ON THE SHAFT. BEARING MUST BE SEATED TIGHT AGAINST THE STOP. PRESS ONLY ON THE INNER RACE OF THE BEARING CONE, NOT ON THE ROLLERS. INSTALL THE STATIONARY AND ROTATING DISCS ON THE SHAFT. NOTE THE ORDER OF THE DISCS IN RELATIONSHIP TO THE ENDS OF THE SHAFT. PRESS THE OTHER CONE ONTO THE SHAFT OBSERVING THE PRECEDING CAUTIONS.
5. BRAKE ASSEMBLY:  
INSTALL PARTS IN REVERSE ORDER OF DISASSEMBLY LEAVING THE SHAFT SEALS TO LAST. RELEASE THE BRAKE WITH 300 PSI [21 BAR] MINIMUM PRESSURE AND MEASURE THE TORQUE TO ROTATE THE SHAFT. THE FREE ROLLING TORQUE OF THE BRAKE SHAFT IS AN INDICATION OF BEARING SEATING AND FIT. THE ROLLING TORQUE SHOULD BE 5 IN-LB [0.6 Nm] MAXIMUM. IF BRAKE DOES NOT MEET THIS SPECIFICATION, CHECK THAT THE BEARINGS ARE WELL SEATED.
6. LIP SEAL ASSEMBLY:  
AFTER THE BRAKE IS ASSEMBLED, INSTALL THE SHAFT SEALS. USE CAUTION NOT TO CUT THE SEAL LIPS ON THE SHAFT SPLINES. THE SEALS ARE INSTALLED WITH WIPER FACING OUTWARDS, AWAY FROM THE BRAKE. THE SEALING LIP WILL FACE INWARDS. SEE CUTAWAY VIEW FOR SEAL ORIENTATION DETAIL.

## OIL FILL PROCEDURE:

REMOVE OIL LEVEL PLUG. FILL BRAKE WITH DTE-26 UNTIL OIL DRIPS FROM FILL/LEVEL PORT. REINSTALL PLUG AND TIGHTEN.

## SERVICE KIT INFORMATION:

- BEARING KIT: PK.1931 - INCLUDES SEALS, RETAINING RINGS, AND BEARINGS.
- STACK KIT: PK.1504 - INCLUDES TORQUE PINS, PRIMARY, STATIONARY, AND ROTATING DISCS.
- O-RING KIT: PK.1503 - INCLUDES O-RINGS AND INTERNAL GASKET.

REF: GENERAL ASSEMBLY VIEW 8007

W  
**PRO/E**

ITEM	PART	DESCRIPTION	QTY
1	80186	PAINTED HOUSING	1
2	74863	SPRING RETAINER	1
3	36385	COMPRESSION SPRING	18
4	36384	COMPRESSION SPRING	18
5	83856	SPLINED SHAFT	1
6	90118	TAPERED ROLLER BEARING (CONE)	2
7	90119	TAPERED ROLLER BEARING (CUP)	2
8	74849	PRIMARY DISC	1
9	37176	PRESSURE RELIEF VALVE	1
10	89567	ROTATING DISC	7
11	74857	STATIONARY DISC	7
12	74842	GASKET	1
13	93667	PAINTED POWER PLATE	1
14	74843	O-RING	1
15	74846	PISTON	1
16	74847	O-RING	1
17	80992	OIL SEAL	2
18	75418	WASHER	1
19	74923	NUT	1
20	75414	RETAINING RING	1
21	75676	SPACER	1
22	84580	SHIM	*
23	86049	SHIM	*
24	29558	TORQUE PIN	2
25	74539	HEX BOLT FLANGE	6
26	36673	PROTECTIVE PLUG	1
27	35553	HEX HEAD PLUG	2
28	75970	CAUTION TAG	1

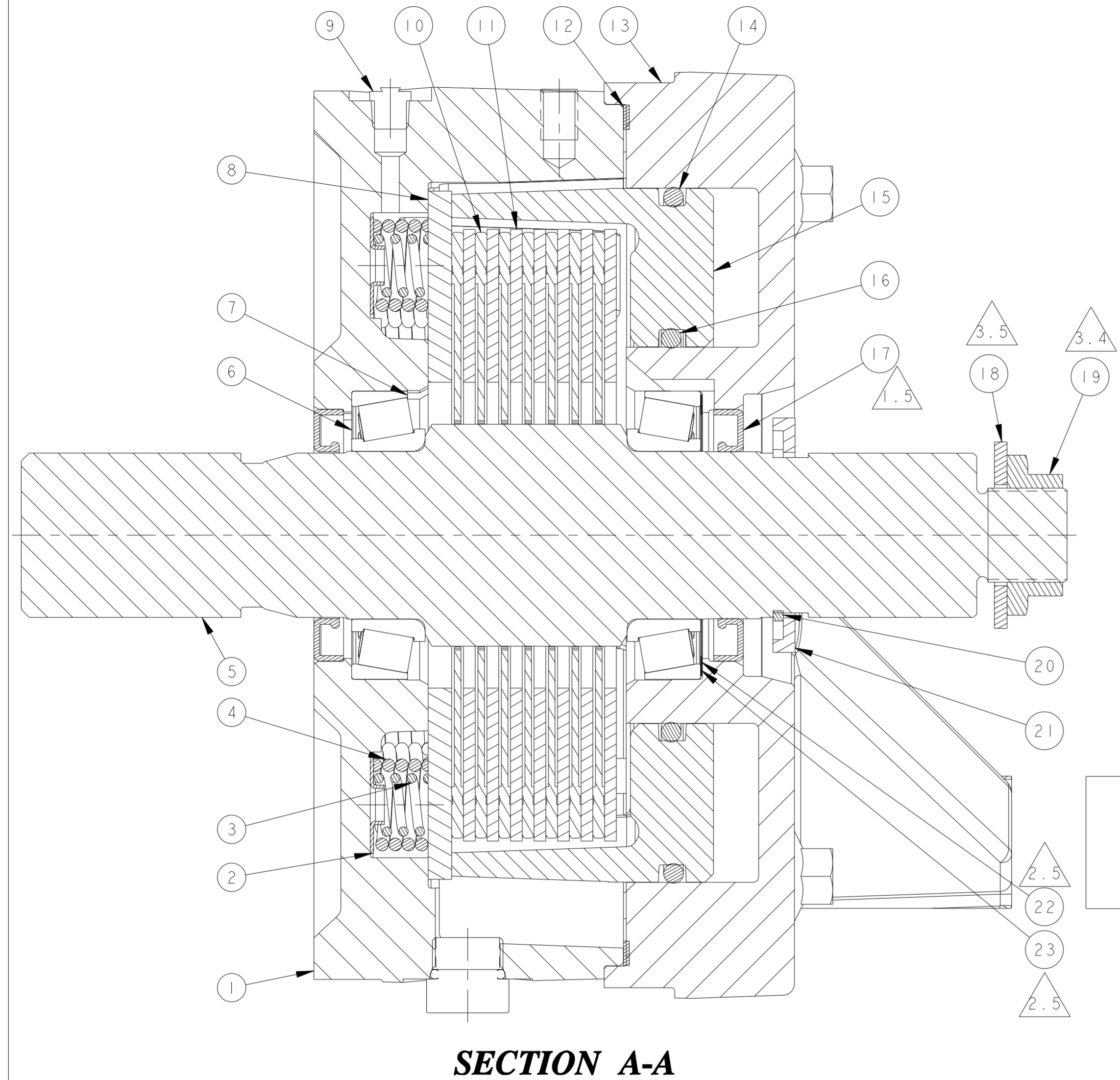

**SECTION A-A**

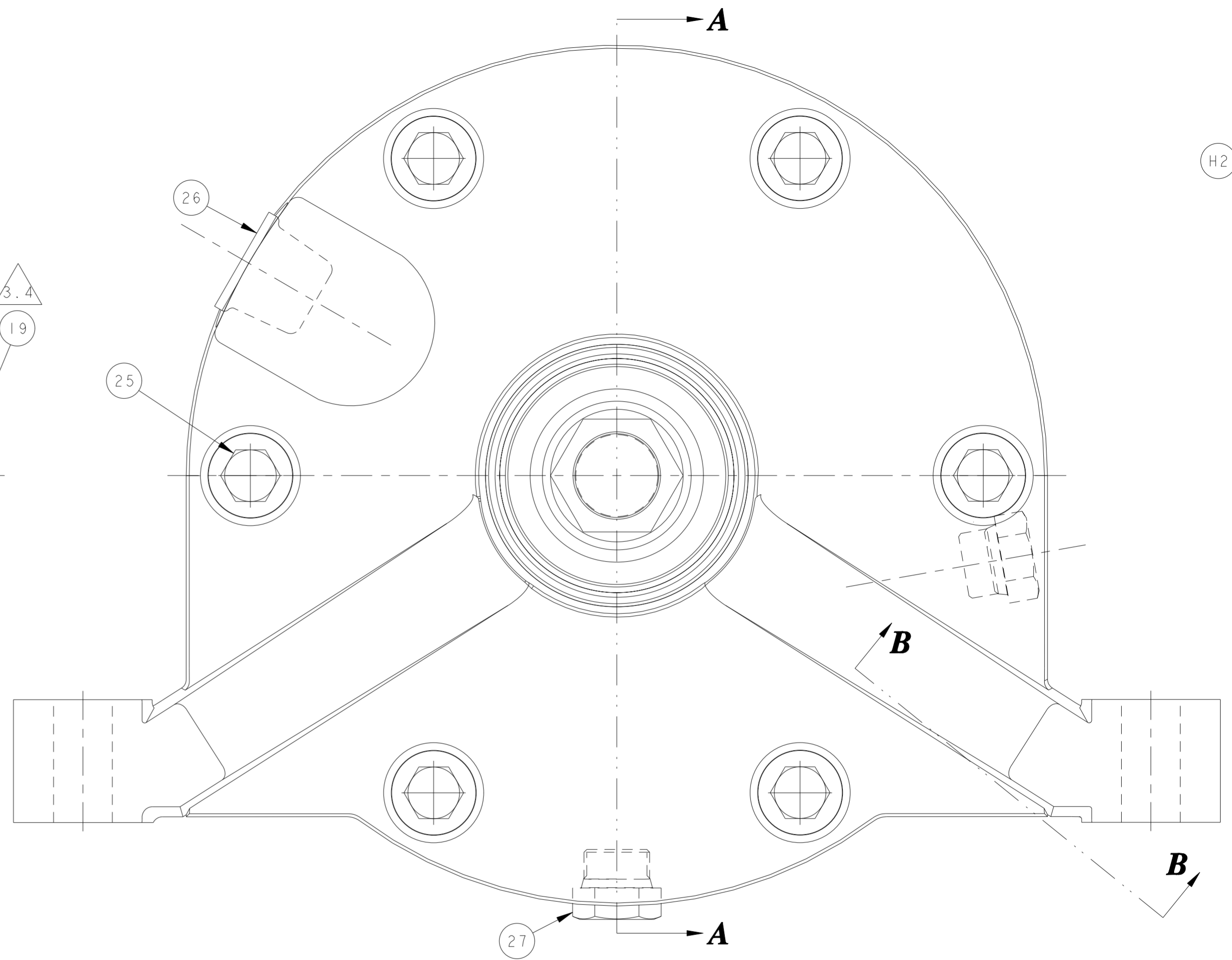

**SECTION B-B**

**ASSEMBLY:**

- 1.1 PRIOR TO ASSEMBLY, LUBRICATE THE FOLLOWING WITH DOW CORNING 200.
  - 1.1.1 SIDE OF PISTON GROOVE IN POWER PLATE
  - 1.1.2 O-RING GROOVES IN PISTON
  - 1.1.3 O-RINGS
  - 1.1.4 LIP OF SEALS
  - 1.1.5 BEARINGS
- 1.2 BOLT ASSEMBLY TORQUE: 70-80 FT LBS [94-108 Nm]; BOLTS TO BE LUBRICATED.
- 1.3 TORQUE PRESSURE RELIEF VALVE TO 10-15 FT-LBS [13-20 Nm].
- 1.4 TORQUE HEX PLUGS TO 45-55 FT-LBS [61-75 Nm].

1.5 APPLY LOCTITE 515 TO THE OUTSIDE DIAMETER OF THE OIL SEAL IN THE HOUSING AND THE POWER PLATE.

**TEST PROCEDURE:**

- 2.1 HYDRAULIC FLUID USED DURING TEST TO CONFORM TO DTE-26.
- 2.2 MOUNT ON SUITABLE FIXTURE. MOUNTING BOLTS MUST BE SECURE.
- 2.3 RELEASE PRESSURE: SLOWLY INCREASE PRESSURE TO THE BRAKE UNTIL THE SHAFT ROTATES FREELY. ACCEPTABLE RANGE: 125-155 PSI [8-11 BAR].
- 2.4 CONTACT PRESSURE: INCREASE PRESSURE TO 300 PSI [21 BAR] HIGHER THAN THE

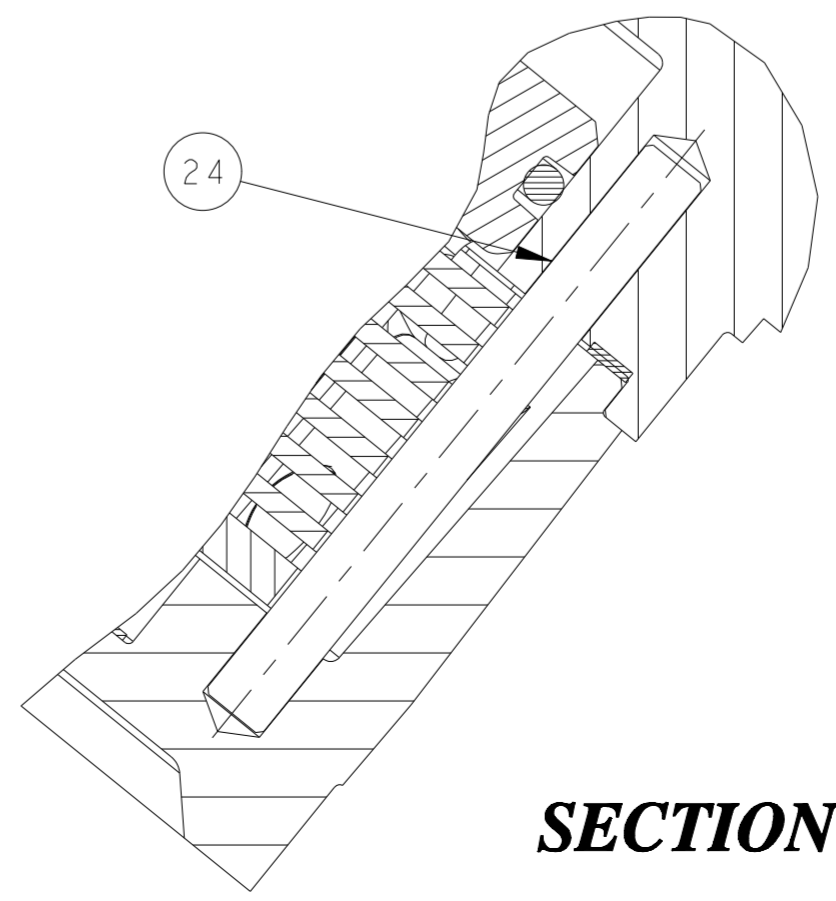

# GENERAL ASSEMBLY VIEW

THIS DRAWING PROVIDES GENERAL GUIDELINES AND ASSEMBLY INFORMATION ON AUSCO MULTI-DISC BRAKES. CONFIGURATION OF BRAKES VARIES FROM MODEL TO MODEL. CONSULT YOUR BRAKES SERVICE NOTES, BILL OF MATERIAL, AND CUTAWAY VIEW FOR EXACT DETAILS.

