

THE MULTI DISC BRAKE WITH SERVICE IS A SPRING APPLIED BRAKE. WITH AN INDEPENDENT SERVICE FEATURE. HYDRAULIC PRESSURE IS REQUIRED TO RELEASE OR "HOLD OFF" THE BRAKE. NORMAL OPERATION IS TO HAVE THE BRAKE PRESSURIZED IN THE RELEASED POSITION WITH THE VEHICLE HYDRAULIC SYSTEM RUNNING. ANY FUNCTION WHICH REDUCES THE HYDRAULIC SYSTEM PRESSURE BELOW THE RELEASE PRESSURE OF THE BRAKE WILL CAUSE THE BRAKE TO BE APPLIED. IN ADDITION, THE BRAKE MAY BE APPLIED VIA SEPERATE HYDRAULIC SYSTEM CONNECTED TO THE SERVICE BRAKE INLET. PRESSURE IN THIS CIRCUIT WILL APPLY THE BRAKE, AND THE BRAKE TORQUE WILL BE DIRECTLY PROPORTIONAL TO THE AMOUNT OF PRESSURE APPLIED. THE FAILSAFE PORTION OF THE BRAKE WILL NOT BE AFFECTED.

INSTALLATION INFORMATION:

1. PLACE THE GASKET ONTO THE MOUNTING FACE OF THE BRAKE.
2. PLACE THE BRAKE INTO THE GEAR REDUCER WITH BLEEDER SCREW IN THE VERTICAL POSITION IF POSSIBLE.
3. MOVE THE BRAKE INTO POSITION WITH THE GEAR REDUCER MAINTAINING PROPER GASKET LOCATION. ALIGN THE MOUNTING BOLT HOLES BY ROTATING THE ENGAGED BRAKE INTO POSITION. IF THIS IS NOT POSSIBLE, THE BRAKE MAY BE ROTATED AFTER PRESSURE HAS BEEN APPLIED TO THE BRAKE INLET. THIS WILL RELEASE THE BRAKE AND ALLOW IT TO BE ROTATED INTO POSITION.
4. SIMILARLY, PLACE THE GASKET ONTO THE FLANGE OF THE MOTOR.
5. INSERT THE SHAFT OF THE MOTOR INTO THE BRAKE AND PUSH INTO POSITION MAINTAINING PROPER GASKET LOCATION.
6. INSERT FOUR 1/2 INCH DIAMETER BOLTS (GRADE 5) THROUGH THE BRAKE, GASKET AND INTO THE GEAR REDUCER MOUNTING FLANGE. MAKE SURE THAT THE BOLTS ARE NOT TOO LONG. TO PREVENT BINDING, RUN THE BOLTS ALTERNATELY UNTIL SNUG. THEN TORQUE THE BOLTS TO 75-85 FT-LBS. NOTE: BOTH SHAFTS MUST SLIDE TOGETHER FREELY. DO NOT USE THE BOLTS TO FORCE THE UNIT TOGETHER.)
7. INSERT FOUR 7/16 INCH DIAMETER BOLTS (GRADE 5) THROUGH THE MOTOR FLANGE, THE GASKET, AND INTO THE THREADED HOLES OF THE BRAKE. MAKE SURE THAT THE BOLTS ARE NOT TOO LONG. TO PREVENT BINDING, RUN THE BOLTS IN ALTERNATELY UNTIL SNUG. THEN TORQUE THE BOLTS TO 50-60 FT LBS.
8. CONNECT INLET HYDRAULIC LINES TO HOUSING AND POWER PLATE. CONNECT FLOW THRU LINES PER CUTAWAY VIEW.

BRAKE DISASSEMBLY INFORMATION:

1. WITH SHAFT PROTRUSION DOWNWARD, DISASSEMBLE IN THE FOLLOWING ORDER:
BOLTS ALTERNATELY (USE EXTREME CAUTION-SPRINGS WILL CAUSE POWER PLATE ASSEMBLY TO POP OFF HOUSING AS SOON AS BOLTS ARE RELEASED). POWER PLATE ASSEMBLY, SPRINGS, O-RINGS, STATIONARY DISCS, ROTATING DISCS, PRIMARY DISC, SECONDARY DISCS, PINS, AND SPRINGS.
2. FURTHER DISASSEMBLY IS NOT RECOMMENDED AND SHOULD NOT BE ATTEMPTED UNLESS NECESSARY TO REPLACE THE BEARING, THE SEAL, OR THE SHAFT.
NOTE: IF THE BEARING AND SEAL ARE REMOVED FOR ANY REASON, BOTH MUST BE REPLACED.
 - 2a. REMOVE SNAP RINGS AS NEEDED.
 - 2b. SEAL CAN BE REMOVED BY PRYING IT OUT WITH AN APPROPRIATE TOOL. TAKE CARE NOT TO DAMAGE THE BORE.
 - 2c. SHAFT CAN BE REMOVED BY PRESSING IT OUT WITH A SHOP PRESS.
3. REMOVE PISTON FROM HOUSING BY INTRODUCING LOW PRESSURE AIR TO THE HYDRAULIC INLET. MAKE SURE THE PISTON IS DIRECTED AWAY FROM THE OPERATOR. REMOVE O-RINGS.
4. REMOVE THE PISTON FROM THE POWER PLATE BY INTRODUCING LOW PRESSURE AIR (15 psi) INTO THE HYDRULIC INLET. MAKE SURE THE PISTON IS DIRECTED AWAY FROM THE OPERATOR. REMOVE O-RINGS AND BACKUP RINGS FROM THE O.D. AND I.D. GROOVES OF THE PISTON. BACKUP RINGS WILL BE DAMAGED AND SHOULD NOT BE REMOVED IF REPLACEMENT IS NOT PLANNED. REMOVE SNAP RING, BEARING MAY BE REMOVED BY TAPPING LIGHTLY WITH A PLASTIC Mallet.

ASSEMBLY INFORMATION:

IMPORTANT: THERE MAY BE MORE PARTS IN A SERVICE KIT THAN YOUR BRAKE REQUIRES. CHECK THE PARTS LIST CAREFULLY FOR THE EXACT QUANTITY.

USE THE REVERSE OF THE DISASSEMBLY PROCEDURE WITH THE FOLLOWING NOTES AND ADDITIONS:

1. WORN AND DAMAGED O-RINGS OR WORN BACKUP RINGS MUST BE REPLACED PRIOR TO REASSEMBLY.
2. CYLINDER OF THE POWERPLATE, PISTON, AND O-RINGS MUST BE PRE-LUBED WITH SYSTEM HYDRAULIC FLUID PRIOR TO REASSEMBLY.
3. PISTON ASSEMBLY:
ASSEMBLE PISTON INTO POWER PLATE USING A SHOP PRESS. TAKE CARE NOT TO DAMAGE THE O-RING OR TEFLON BACKUP RINGS. VISUALLY ALIGN THE CENTER OF THE CUTOUTS IN THE PISTON WITH THE TORQUE PIN HOLES IN THE POWER PLATE.
CAUTION: THE DEPTH THE PISTON IS INSTALLED INTO THE POWER PLATE IS CRITICAL. THE SURFACE OF THE PISTON AT THE CUTOUTS MUST BE FLUSH TO 0.120 BELOW THE SURFACE OF THE POWER PLATE OR PISTON WILL COCK RESULTING IN A COMPLETE LOSS OF BRAKING.
4. BEARING ASSEMBLY:
USE A SHOP PRESS TO PRESS THE BEARING ONTO THE SHAFT. PRESS ONLY ON THE INNER RACE OF BEARING. BEARING IS A SLIP FIT TO THE HOUSING.
5. LIP SEAL ASSEMBLY:
LIP OF SEAL MUST FACE TOWARDS THE BEARING. SEE CUTAWAY VIEW FOR SEAL ORIENTATION DETAIL.
6. ROTATING, STATIONARY, SECONDARY, AND PRIMARY DISC ASSEMBLY: ROTATING DISC MUST BE CLEAN. THE LINING MATERIAL AND MATING SURFACES OF THE STATIONARY DISCS MUST BE THOROUGHLY CLEAN AND FREE FROM DEBRIS. WORN OR SCARRED ROTATING DISCS MUST BE REPLACED.
7. INSTALL BOLTS IN THE POWER PLATE. TIGHTEN SEQUENTIALLY ONE TURN AT A TIME UNTIL POWER PLATE IS PROPERLY SEATED. TORQUE BOLTS TO 80-90 FT-LBS.

OIL FILL PROCEDURE:

UNSCREW THE TOP OIL FILL PLUG AND ADD DTE-26 OIL TO THE APPROPRIATE LEVEL.
HORIZONTAL POSITION: 195 mL
VERTICAL POSITION: FOR AMOUNT OF OIL, CONTACT AUSCO

SERVICE KIT INFORMATION:

- BEARING KIT: PK-1696 - INCLUDES SEALS, RETAINING RINGS, AND BEARINGS.
- STACK KIT: PK-1697 - INCLUDES TORQUE PINS, PRIMARY, STATIONARY, ROTATING, & SECONDARY DISCS, & COMPRESSION SPRINGS.
- O-RING KIT: PK-1698 - INCLUDES O-RINGS & BACKUP RINGS
- GASKET KIT: PK-1700 - INCLUDES EXTERIOR GASKET(S).

ITEM	PART	DESCRIPTION	QTY
1	90438	HOUSING	1
2	28427	GASKET	1
3	29952	O-RING	1
4	82538	SERVICE PISTON	1
5	79521	O-RING	1
6	28284	BEARING	2
7	84899	OIL SEAL	1
8	84844	SHAFT	1
9	28285	RETAINING RING	1
10	82543	PRIMARY DISC	1
11	82540	SECONDARY DISC	2
12	29035	BLEEDER SCREW	2
13	75072	STATIONARY DISC	5
14	90730	ROTATING DISC	6
15	75395	PLUG	3
16	79708	O-RING	1
17	32833	BACKUP RING	1
18	36701	O-RING	1
19	84754	POWER PLATE	1
20	82542	PISTON	1
21	27967	BACKUP RING	1
22	27808	O-RING	1
23	31218	HEX FLANGE SCREW	2
24	30468	GASKET	1
25	28811	HEX PLUG	1
26	28435	PROTECTIVE PLUG	2
27	80174	COMPRESSION SPRING	18
28	29558	TORQUE PIN	4
29	82546	COMPRESSION SPRING	2
30	36326	PROTECTIVE PLUG	2
31	84653	O-RING	6
32	86057	COMPRESSION SPRING	18

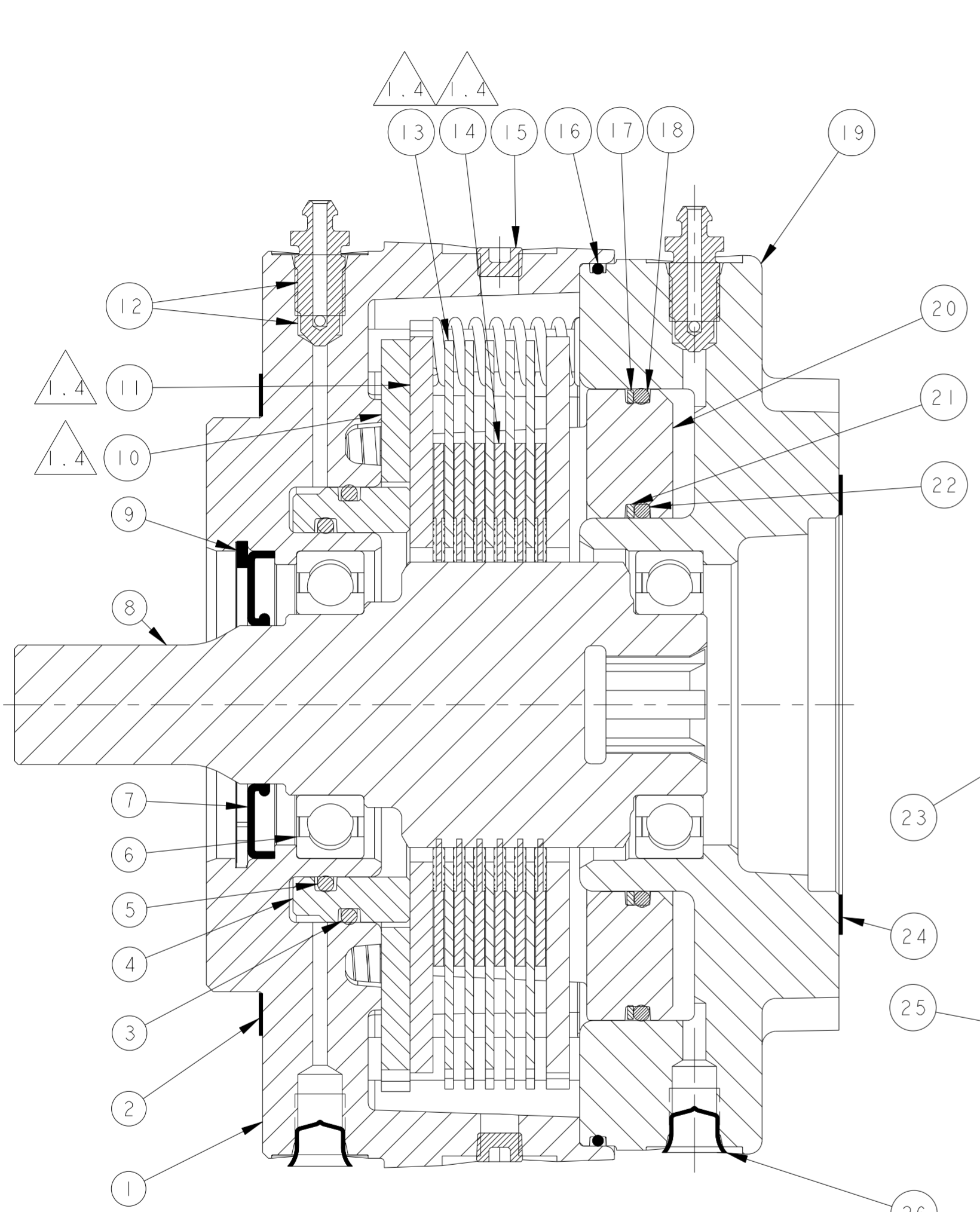

SECTION A-A

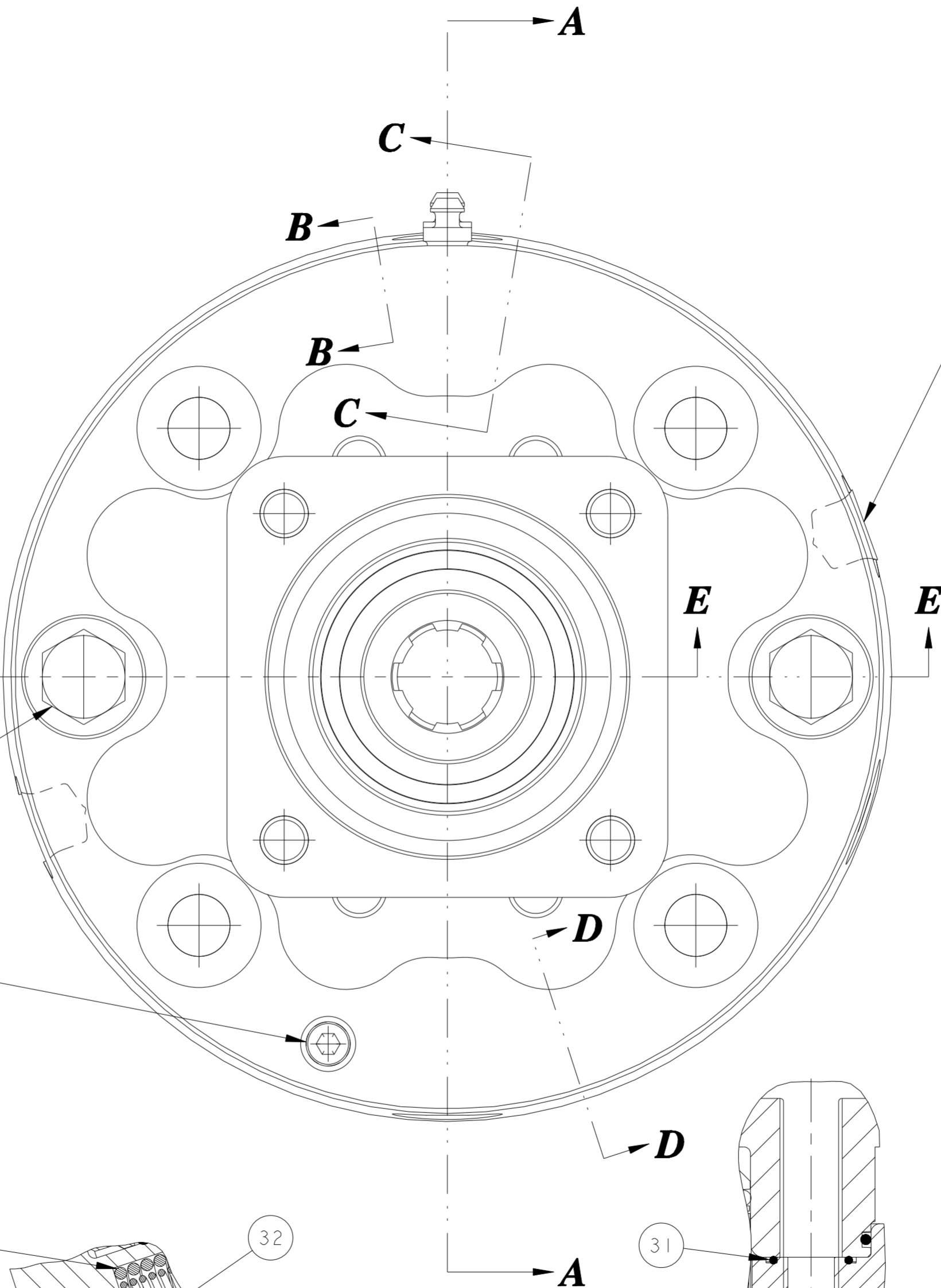

SECTION E-E

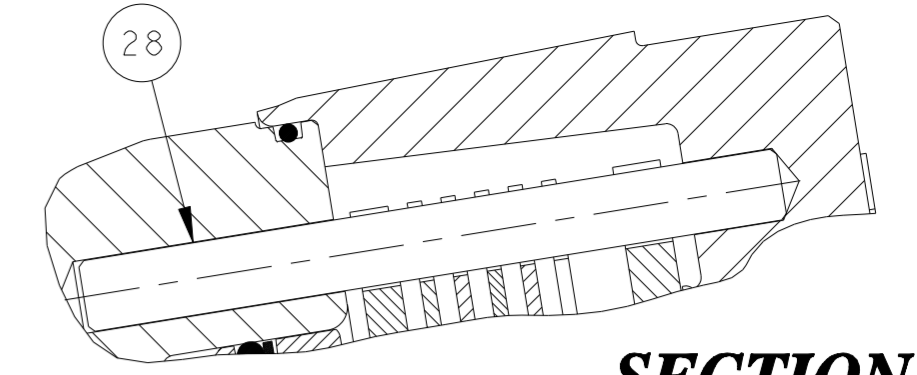

SECTION B-B

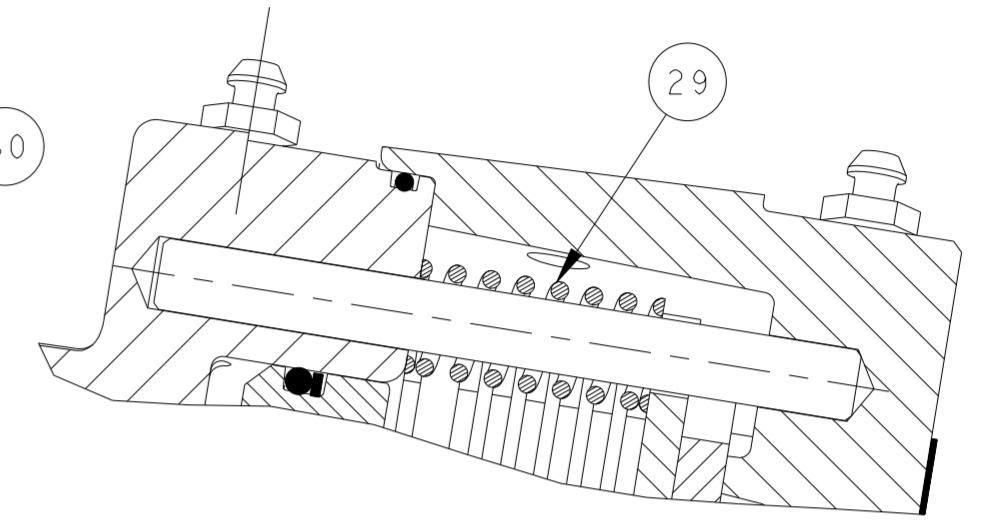

SECTION C-C

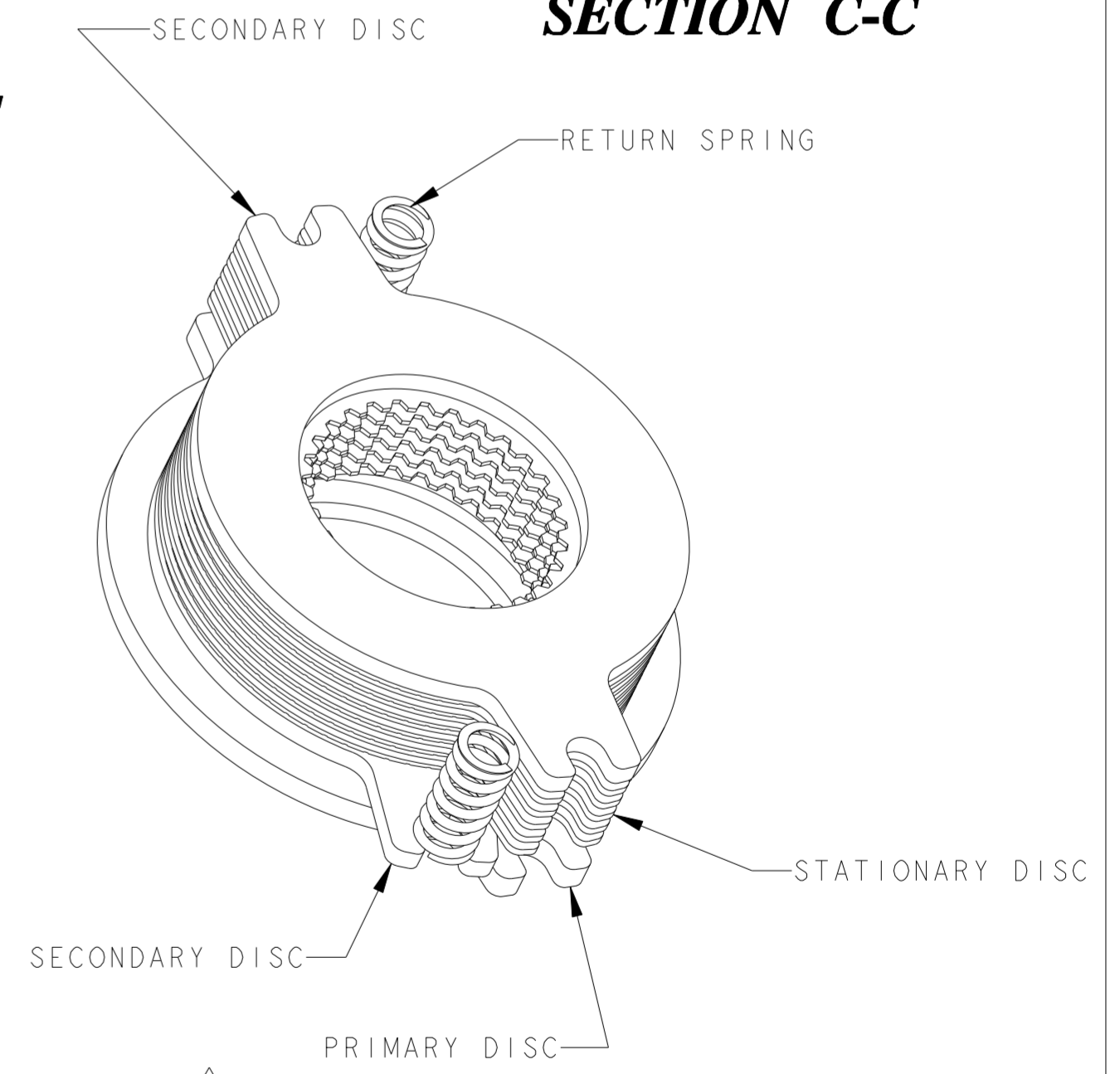

1.4 **DISC STACK ORIENTATION**
NO SCALE

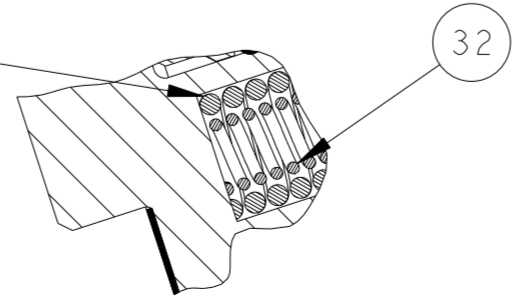

SECTION D-D

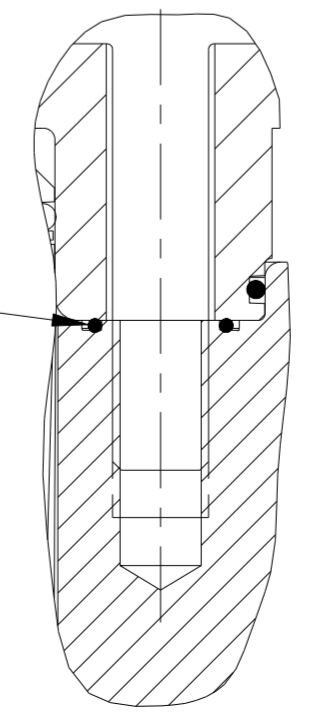

SECTION D-D



STANDARD FAILSAFE W/SERVICE BRAKES GENERAL ASSEMBLY VIEW

NOTE: THIS DRAWING PROVIDES GENERAL GUIDELINES AND ASSEMBLY INFORMATION ON AUSCO MULTI-DISC BRAKES. CONFIGURATION OF BRAKES VARIES FROM MODEL TO MODEL. CONSULT YOUR BRAKES SERVICE NOTES, BILL OF MATERIAL, AND CUTAWAY VIEW FOR EXACT DETAILS.

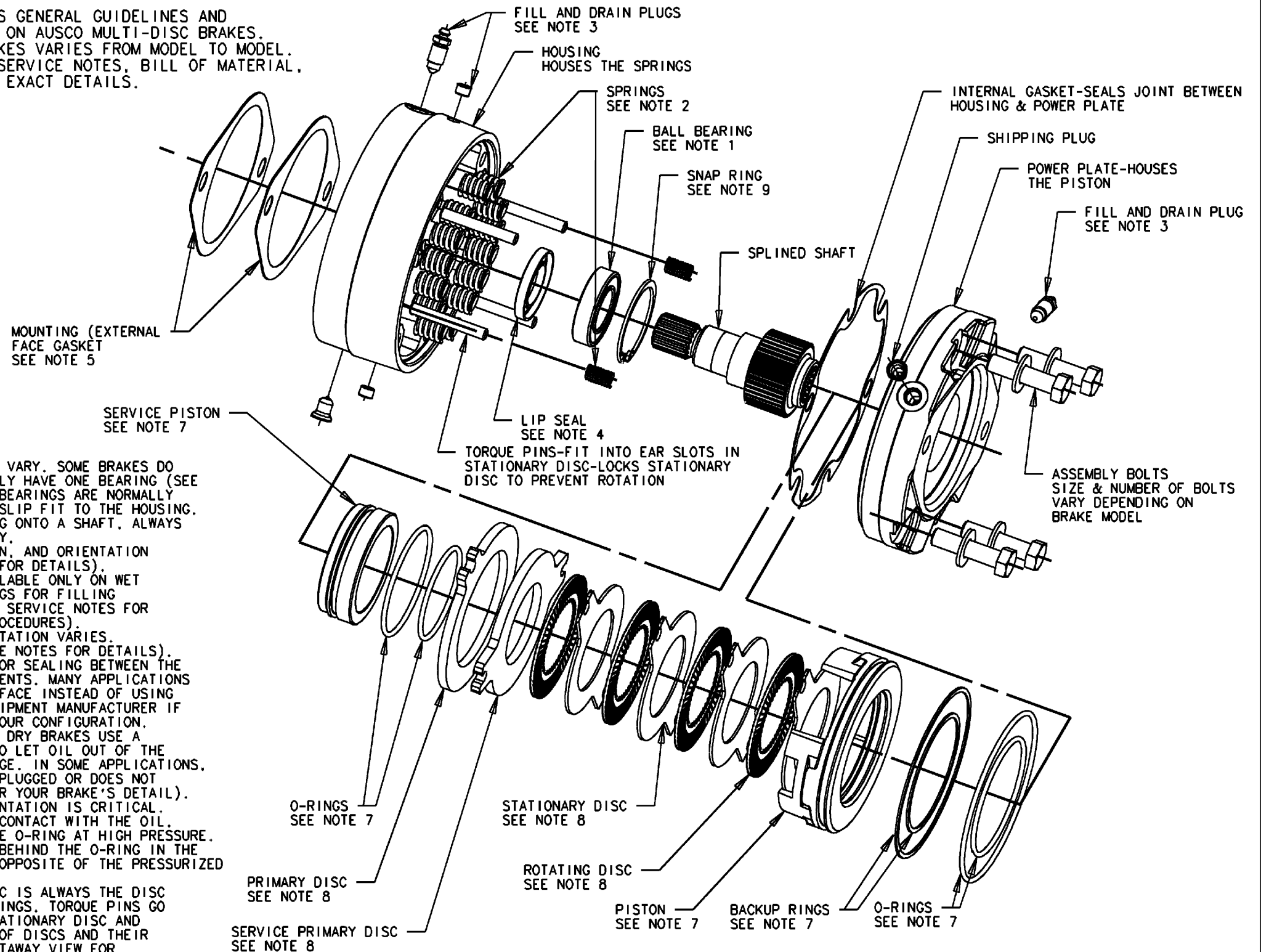

NOTES:

1. BALL BEARING CONFIGURATIONS VARY. SOME BRAKES DO NOT HAVE A BEARING, SOME ONLY HAVE ONE BEARING (SEE CUTAWAY VIEW FOR DETAILS). BEARINGS ARE NORMALLY PRESSED ONTO THE SHAFT AND SLIP FIT TO THE HOUSING. WHENEVER YOU PRESS A BEARING ONTO A SHAFT, ALWAYS PRESS ON THE INNER RACE ONLY.
2. SPRING DESIGN, CONFIGURATION, AND ORIENTATION VARIES. (SEE CUTAWAY VIEW FOR DETAILS).
3. FILL & DRAIN PLUGS ARE AVAILABLE ONLY ON WET BRAKE MODELS. USE THESE PLUGS FOR FILLING BRAKE CAVITY WITH OIL. (SEE SERVICE NOTES FOR INSTRUCTIONS ON OIL FILL PROCEDURES).
4. LIP SEAL POSITION AND ORIENTATION VARIES. (SEE CUTAWAY VIEW AND SERVICE NOTES FOR DETAILS).
5. MOUNTING GASKETS ARE USED FOR SEALING BETWEEN THE BRAKE AND ITS MATING COMPONENTS. MANY APPLICATIONS USE AN O-RING TO SEAL THIS FACE INSTEAD OF USING THE GASKET. CONSULT THE EQUIPMENT MANUFACTURER IF YOU ARE IN QUESTION AS TO YOUR CONFIGURATION.
6. PRESSURE RELIEF VALVE. SOME DRY BRAKES USE A LOW PRESSURE RELIEF VALVE TO LET OIL OUT OF THE BRAKE IN THE EVENT OF LEAKAGE. IN SOME APPLICATIONS, THE PORT FOR THIS VALVE IS PLUGGED OR DOES NOT EXIST. (SEE CUTAWAY VIEW FOR YOUR BRAKE'S DETAIL).
7. O-RING AND BACKUP RING ORIENTATION IS CRITICAL. O-RING SHOULD ALWAYS BE IN CONTACT WITH THE OIL. THE BACKUP RING SUPPORTS THE O-RING AT HIGH PRESSURE. IT SHOULD ALWAYS BE PLACED BEHIND THE O-RING IN THE O-RING GROOVE, ON THE SIDE OPPOSITE OF THE PRESSURIZED OIL.
8. NOTES ON STACK. PRIMARY DISC IS ALWAYS THE DISC DIRECTLY CONTACTING THE SPRINGS. TORQUE PINS GO THROUGH THE SLOTS IN THE STATIONARY DISC AND PRIMARY DISCS. THE NUMBERS OF DISCS AND THEIR ORIENTATION VARIES. (SEE CUTAWAY VIEW FOR DETAILS). IT IS IMPORTANT THAT THE STACK IS CONFIGURED CORRECTLY FOR YOUR APPLICATION OR BRAKE FUNCTION MAY BE COMPROMISED.
9. SNAP RING CONFIGURATION VARIES. (SEE CUTAWAY VIEW FOR DETAILS).

FILE: 8005 STD FAILSAFE
CURRENT REV: EC020236 REV A